

**G.N. (S.) 3 of 2017**

FIRE SERVICES ORDINANCE (Chapter 95)

FIRE SERVICE (INSTALLATIONS AND EQUIPMENT) REGULATIONS  
(Chapter 95)

Pursuant to regulation 10(3)(a) of the Fire Service (Installations and Equipment) Regulations, the following is the Code of Practice prescribed by me under regulation 10(1).

## CODE OF PRACTICE

FOR

INSPECTION, TESTING AND MAINTENANCE

OF INSTALLATIONS AND EQUIPMENT

**CODE OF PRACTICE FOR INSPECTION, TESTING AND MAINTENANCE OF  
INSTALLATIONS AND EQUIPMENT**

**PRELIMINARY NOTE**

Pursuant to Section 21(6)(d) of the Buildings Ordinance, the Building Authority may refuse to issue a temporary occupation permit or an occupation permit where in the case of a building the plans whereof were certified by the Director of Fire Services in the terms indicated in Section 16(1)(b)(ii) of the Buildings Ordinance, the applicant for the permit fails to produce to the Building Authority a certificate from the Director of Fire Services in such form as may be prescribed certifying that he is satisfied that the fire service installations and equipment shown on the plans aforesaid have been provided and are in efficient working order and satisfactory condition.

This Code of Practice for Inspection, Testing and Maintenance of Installations and Equipment is published in accordance with Regulation 10 of the Fire Service (Installations and Equipment) Regulations of the Fire Services Ordinance, Cap. 95 to indicate the type and nature of inspections and tests which installations and equipment must normally pass in order to satisfy the Director of Fire Services and to give guidance as to the conduct of inspections and tests. It does not lay down any hard and fast rules. Special factors and circumstances may require variations in respect of any particular building, and in particular case the Director may require additional inspections or tests before he is so satisfied.

**Part I GENERAL**

- 1.1 Inspection and acceptance testing shall be carried out by a Fire Services Inspecting Officer by arrangement with the Authorized Person and the registered fire service installation contractor (RFSIC).
- 1.2 Applications for initial inspection and testing should be made on the prescribed form to the Director of Fire Services. The form must be signed by both the RFSIC and the Authorized Person.
- 1.3 An application should only be submitted by the Authorized Person when the installation and equipment has been installed, completed and certified as being in efficient working order by the RFSIC.
- 1.4 Upon receipt of an application the Fire Services Inspecting Officer will contact the Authorized Person (not the RFSIC) at the telephone number shown on the prescribed form, and arrange a mutually convenient inspection date. The Authorized Person, as the co-ordinator of the project, should attend the inspection and it is also his responsibility to contact and inform the RFSIC of the arrangements made.
- 1.5 A further prescribed form will be used to record the result of the inspection and will be completed and signed on site by the Fire Services Inspecting Officer. The Authorized Person and the RFSIC will also be required to sign this form confirming that the results of the inspection have been brought to their attention.
- 1.6 In respect of minor items requiring a further inspection the Authorized Person will, after the defects have been rectified, arrange a re-inspection date with the Senior Building Services Inspector, Fire Service Installations Division. A further formal application for inspection on the prescribed form will only be required when a refusal letter has been issued subsequent to an inspection.
- 1.7 Re-inspections will be carried out as convenient, subject only to the availability of Inspecting Officer and provided that previous confirmed appointments are not affected.
- 1.8 Subsequent to a satisfactory inspection, the Authorized Person will be notified by telephone as soon as the Fire Services Certificate (F.S. 172) is ready for collection. If unable to be contacted by telephone a "ready for collection" letter will be despatched.

- 1.9 The Certification of Completion by the Water Authority in respect of fire service installations (FSI) requiring Government water mains connection will be sent direct to the Building Authority by the Water Authority, copied to the applicant, after the installation has been inspected and approved by the Water Authority and the fire service connection completed.
- 1.10 The FSI for a building for which a temporary occupation permit or occupation permit has been issued must be maintained, inspected and certified by a RFSIC at least once in every 12 months. Whenever a RFSIC maintains or inspects any FSI in any premises, he shall forward a certificate (Certificate of Fire Service Installations and Equipment (F.S. 251)) to the Director of Fire Services. A summary of statutory requirements for maintenance, inspection and repair of FSI and examination, testing and certification of gas cylinders used as FSI to be observed by RFSIC is enclosed at APPENDIX 10.
- 1.11 The certificate for annual inspection of fire service installations together with a list of the fire service installations and equipment should be displayed in a prominent area of the building by the RFSIC in consultation with the owner or building management.
- 1.12 Design engineers and RFSIC should advise the owner of the building, or his agent that any fire service installation or equipment (such as the staircase pressurization system etc.), which would normally be left in idle or standby conditions except in case of fire, should be actuated and checked by the owner or his agent at an interval of not more than three months to ensure that the installation or equipment are functioning and sequencing correctly.
- 1.13 For any shut-down of building FSI overnight or more than 24 hours continuously, RFSIC shall notify Fire Services Department in accordance with the laid down reporting procedures. RFSIC shall take and advise the residents/occupants/property management company to take preventative measures to mitigate the risk during the works period when any FSI is defective or shut down for inspection, maintenance, modification or repair. A set of procedures and measures to be observed by RFSIC is enclosed at APPENDIX 9.
- 1.14 Fire service installations and equipment which is not included in this Code shall be inspected, tested and maintained in accordance with the manufacturer's recommendations or other acceptable international standards as agreed by the Director of Fire Services.

## Part II INSPECTION, TESTING AND MAINTENANCE

### 2.1 Audio/visual advisory system

#### (i) Acceptance Testing

The system shall be tested in a simulated alarm condition to verify the proper operation and functioning of the audio and visual alarm signals and alarm directives to the satisfaction of the Director of Fire Services.

#### (ii) Maintenance

The system shall be maintained in efficient working order at all times and shall be inspected by a registered fire service installation contractor at least once in every 12 months.

A weekly visual and audio check of all signals should be carried out by the owner or his agent. The system should also be checked in any fire drill.

### 2.2 Automatic actuating devices

#### (i) Acceptance Testing

For fire shutters, roof vents or similar installations, the actuating devices shall be tested to confirm that the designed complete closure or compartment separation of the driven shutters/equipment can be achieved within the time specified.

The testing of automatic actuating devices for fire shutters shall be carried out in accordance with the checklist as laid down at APPENDIX 1. The testing for other similar installations shall be in accordance with the manufacturer's recommendations and other standards as may be prescribed by

the Director of Fire Services on account of specific features of the installations.

**(ii) Maintenance**

The components and devices shall be maintained in efficient working order at all times and shall be inspected by a registered fire service installation contractor at least once in every 12 months.

The fire shutters or roof vents should be regularly checked by the owner or his agent for proper operation in both manual and automatic modes.

**2.3 Automatic fixed installation other than water**

**(i) Acceptance Testing**

CO<sub>2</sub>, FM200 and other similar clean gas extinguishing system shall be checked and tested in accordance with the checklist as laid down at APPENDIX 2 and by direct and/or remote control sequences in accordance with test procedures as laid down in the NFPA 2001 or other acceptable international standard as agreed by the Director of Fire Services.

**(ii) Maintenance**

The system shall be maintained in efficient working order at all times and be inspected by a registered fire service installation contractor at least once in every 12 months.

**2.4 Automatic fixed installation using water**

These may include:

- Deluge system
- Drencher system
- Sprinkler system
- Water mist system
- Water spray system

Acceptance testing and maintenance for the above are described in the respective sections.

**2.5 Deluge system**

**(i) Acceptance Testing**

The system shall be tested in accordance with the manufacturer's recommendations and other requirements as may be prescribed by the Director of Fire Services on account of specific features of the system.

**(ii) Maintenance**

The system shall be maintained in efficient working order at all times and shall be inspected by a registered fire service installation contractor at least once in every 12 months.

**2.6 Drencher system**

**(i) Acceptance Testing**

The system shall be tested to demonstrate the satisfactory performance including water flow rate, working pressure, water spraying pattern, means of actuation and other requirements as may be prescribed by the Director of Fire Services on account of specific features of the system.

**(ii) Maintenance**

The system shall be maintained in efficient working order at all times and shall be inspected by a registered fire service installation contractor at least once in every 12 months.

**2.7 Dust detection system**

**(i) Acceptance Testing**

The system shall be tested in accordance with the manufacturer's recommendations and other requirements as may be prescribed by the Director of Fire Services on account of specific features of the system.

**(ii) Maintenance**

The system shall be maintained in efficient working order at all times and shall be inspected by a

registered fire service installation contractor at least once in every 12 months.

Tests appropriate to the system should be carried out by the owner or his agent at intervals as recommended by the equipment manufacturer and agreed with the Director of Fire Services. If the system is capable of being actuated manually, such manual actuation should be tested to confirm subsequent operations.

## 2.8 Emergency generator

### (i) Acceptance Testing

On completion of the installation a full test of the fire service installations in a building or premises shall be carried out, with all systems connected to the 'normal' electricity supply.

Upon satisfactory testing of the fire service installations on 'normal' electricity supply, the 'normal' electricity supply shall be switched off, and the emergency generator shall start automatically.

When the emergency generator has gained its capacity and is ready to accept the fire service installations load, each fire service installation shall be switched on until all installations are in operating conditions. A 'simultaneous running' test shall then take place and shall last for a continuous period of one hour. During this period the performance of each fire service installation shall be monitored.

After one hour of testing, the emergency generator set shall be examined and all instruments, safety devices, etc. shall indicate 'normal' running of the generator.

A checklist for testing of emergency generator installation is enclosed at APPENDIX 3.

### (ii) Maintenance

The emergency generator shall be maintained in efficient working order at all times and shall be inspected by a registered fire service installation contractor at least once in every 12 months.

Moreover, all units should be run once per month under load conditions for a period of not less than 30 minutes by the owner or his agent. During this running period all operating conditions should be checked. Following this running period functional tests should be carried out on all automatic and manual starting devices and safety controls.

A log book should be provided, and retained in the plant room, management office or building supervisor office, and should be kept up to date by the owner or his agent. The record should be made at the time of occurrence and should include details of all operations; faults and corrective actions taken, routine servicing, maintenance and periodic operation etc.; including dates, times, hour meter readings, workers/supervisors names and signatures, etc. for the unit, batteries, compressors, etc.

Further routine testing and maintenance for a particular installation may be required by the Director of Fire Services.

Fuel tanks shall be refilled to full after testing.

## 2.9 Emergency lighting

### (i) Acceptance Testing

Tests shall be carried out in accordance with British Standard 5266 : Part 1 and BS EN 1838 or in such manner as may be prescribed by the Director of Fire Services on account of specific features of the equipment.

### (ii) Maintenance

All emergency lighting shall be maintained in efficient working order at all times and shall be inspected by a registered fire service installation contractor at least once in every 12 months. The following maintenance procedures should be arranged by the owner or his agent:

- a. Once every month a discharge test, for 1 minute at the 10-hour discharge rate, should be carried out on the battery of the emergency lighting, and the results should be entered in a register. The on-load voltage of each cell after this test should be not less than 2.01 volts for lead acid and 1.25 volts for nickel cadmium battery.

b. Voltage and hydrometer tests should be carried out weekly and recorded in a register.

#### 2.10 Exit sign

##### (i) Acceptance Testing

Tests shall be carried out in accordance with British Standard 5266: Part 1 or in such manner as may be prescribed by the Director of Fire Services on account of specific features of the equipment.

##### (ii) Maintenance

All exit sign shall be maintained in efficient working order at all times and shall be inspected by a registered fire service installation contractor at least once in every 12 months. Moreover, exit sign should be tested whenever an emergency lighting system is tested.

#### 2.11 Fire alarm system

##### (i) Acceptance Testing

Manual fire alarm call points shall be tested together with automatic fire alarm when the whole system is required to be tested in accordance with the appropriate standards as required by the Director of Fire Services. Upon actuation of the manual alarm call points, alarm bells in all or designated zones, other audible/visual alarm signals, fire services link, and hydrant/sprinkler water pumps etc. shall be activated. Audibility of alarm bell sound shall be checked at hindered locations of the building/premises. A checklist for testing of fire alarm system is enclosed at APPENDIX 4.

##### (ii) Maintenance

The system shall be maintained in efficient working order at all times and shall be inspected by a registered fire service installation contractor at least once in every 12 months.

Manual fire alarm points should be tested when the whole system is required to be tested in accordance with the appropriate standard.

Attention is drawn to Regulation 38 of the Education Regulations, Chapter 279 in respect of fire alarm testing and fire drills in schools.

#### 2.12 Fire control centre

##### (i) Acceptance Testing

Testing of the fire control panels shall be carried out as part of the testing for various fire service systems in accordance with the appropriate standards or codes as outlined elsewhere in this Code.

Visual check on the integrity of room enclosures for compartmentation with respect to fire resistance rating shall be required. Appropriate certificate by the Authorized Person for the fire resistance rating of the materials/structure should be provided during inspection. Check shall be made on the ready visibility and accessibility of the control panels with regards to the room layout and security fixtures.

##### (ii) Maintenance

Routine check of the provisions such as power supply, lighting and tidiness inside the control centre should be carried out by the owner or his agent.

#### 2.13 Fire detection system

##### (i) Acceptance Testing

The testing of fire detection system shall be carried out in accordance with British Standard 5839-1:2002 + A2:2008 – Fire Detection and Fire Alarm Systems for Buildings (with suitable modifications pertinent to Hong Kong). A checklist for testing of fire detection system is enclosed at APPENDIX 4.

##### (ii) Maintenance

The installation shall be maintained in efficient working order at all times and shall be inspected by a registered fire service installation contractor at least once in every 12 months.

The direct line connection should be tested once every 2 weeks or at such time and interval as agreed by the Director of Fire Services.

**2.14 Fire hydrant/hose reel system****(i) Acceptance Testing**

The system shall be tested in accordance with the checklist laid down at APPENDIX 5.

**(ii) Maintenance**

The installation shall be maintained in efficient working order at all times and shall be inspected by a registered fire service installation contractor at least once in every 12 months.

The owner or his agent should carry out regular checks to ensure the hydrant/hose reel nozzles, valves, fittings etc. remain intact at all times and are not damaged or misused for other purposes.

**2.15 Fire resisting cables for fire service installations****(i) Acceptance Testing**

The cables will be accepted as part of the fire service installation. Certificate of compliance of relevant standards may be required upon request.

**(ii) Maintenance**

The fire resisting cables are considered as integral part of the fire service installation and shall be inspected and maintained in safe and satisfactory condition by a registered fire service installation contractor when inspection to the relevant fire service installation is carried out.

**2.16 Fireman's lift and firefighting and rescue stairway****(i) Acceptance Testing**

Fireman's lift shall be tested by a registered lift engineer in accordance with the requirements stipulated in the Code of Practice for Lift Works and Escalator Works issued by the Director of Electrical and Mechanical Services.

**(ii) Maintenance**

Fireman's lift shall be maintained in efficient working order at all times and in accordance with the requirements stipulated in the Code of Practice for Lift Works and Escalator Works issued by the Director of Electrical and Mechanical Services.

**2.17 Fixed automatically operated approved appliance****(i) Acceptance Testing**

These types of fire extinguishing appliances, either of self-contained operating type or of alarm signal actuating type, shall be tested in accordance with the manufacturer's recommendations or other requirements as may be prescribed by the Director of Fire Services on account of specific features of the appliances.

A check on the content weight shall be made either by weighing or by reference to a pressure gauge or other gauge which may be installed as part of the appliances.

**(ii) Maintenance**

The installation shall be maintained in efficient working order at all times and shall be inspected by a registered fire service installation contractor at least once in every 12 months.

**2.18 Fixed foam system****(i) Acceptance Testing**

The testing procedures shall be in accordance with the manufacturer's recommendations for various items/equipment of the system, and shall be in accordance with the appropriate international standard or other requirements as may be prescribed by the Director of Fire Services on account of specific features of the system.

**(ii) Maintenance**

The installation shall be maintained in efficient working order at all times and shall be inspected by a registered fire service installation contractor at least once in every 12 months.

## 2.19 Gas detection system

### (i) Acceptance Testing

The system shall be tested by allowing sufficient amount of the gas to be released across the detection point and to confirm the proper activation of the detector and efficient operation of all ancillary alarm procedures. Testing shall be carried out in accordance with the manufacturer's recommendations and the appropriate international standard or as required by the Director of Fire Services on account of specific feature of the system.

### (ii) Maintenance

The installation shall be maintained in efficient working order at all times and shall be inspected by a registered fire service installation contractor at least once in every 12 months.

## 2.20 Portable hand-operated approved appliance

### (i) Acceptance Testing

Apart from visual inspection, no specific testing is required. The appliances shall be inspected and certified in efficient working order by a Class 3 registered fire service installation contractor.

### (ii) Maintenance

The appliances shall be maintained in efficient working order at all times and shall be inspected by a Class 3 registered fire service installation contractor at least once in every 12 months.

The tests for portable hand-operated approved appliances shall be carried out periodically in accordance with the appropriate standard and the manufacturer's recommendations.

The guidelines on portable hand-operated approved appliances maintenance is enclosed at APPENDIX 11.

These guidelines are also published in the Fire Protection Notice No. 11 "Notes on Fire Extinguishers (Suitability and Maintenance)".

### (iii) Maintenance Label

All portable extinguishers shall be provided or stuck with a label after maintenance as per the sample in APPENDIX 11. The purpose of this maintenance label is to provide and update all relevant information on the equipment after maintenance.

The label shall not be affixed over the original manufacturer's label on the equipment body, thus covering the name, model and reference number of that equipment.

Indelible and permanent ink shall be used to fill in the label.

Registered fire service installation contractors are reminded that only portable equipment approved by the Fire Services Department and listed in the The Government of the Hong Kong Special Administrative Region Gazette may be installed, and unless the equipment can be readily identified as being approved and listed, the Fire Services Certificate (F.S. 172) shall not be issued.

### Notes on Portable Equipment Maintenance Label

(Including fire extinguisher, fire blanket, sand bucket and fixed type extinguisher)

#### 1. Company Name

Either the name of the company or the company chop should be printed on the space provided. If company name is not applicable, "NA" should be entered and should not be left blank.

#### 2. Registration No.

The registration number of the Class 3 fire service installation contractor responsible for the maintenance of the portable equipment should be filled in.

#### 3. F.S. 251 No.

The number of the relevant Certificate of Fire Service Installations and Equipment (F.S. 251) should be filled in.



4. Maintenance Date

This date means the date when the maintenance of the portable equipment is completed. It should be the same date as shown on the Certificate (F.S. 251).

5. Next Maintenance

This date means 12 months later and should be counted from the date of the last maintenance. If within 12 months period, the fire extinguisher is required to have pressure test, then the date of pressure test should be filled in.

Example: Maintenance Date : 5.9.2003  
Last Pressure Test : 10.7.1999 (pressure test is required for  
every 5 years intervals)  
Next Maintenance : 10.7.2004 (not 5.9.2004)

6. Last Pressure Test

The date shown on the last year's label should be filled in the new label. If last year's label becomes dilapidated or the date cannot be seen when carrying out the maintenance works, the condition of the extinguisher body should be checked to ascertain whether a pressure test is required. If the year of manufacture shown on the extinguisher body exceeds 5 years with no record of pressure test, pressure test should be carried out instead of merely replacing the parts or extinguishing medium.

(For fire blankets and sand buckets, "NA" should be filled in.)

7. Year of Manufacture

According to all standards accepted by the Fire Services Department from different countries, the year of manufacture must be permanently marked or stamped on the extinguisher body. So the year of manufacture can be checked out from the body. If there are only 2 digits, it means the last 2 digits of the year of manufacture, e.g. 99 means manufactured in 1999. For those non-high pressure extinguishers (25 bars below) manufactured according to Malaysian Standard MS1179:1990, it only requires the year of manufacture be clearly marked on the body, but for those Malaysian products manufactured according to BS EN-3, permanent marking or stamp for year of manufacture is shown on the extinguisher body.

(For fire blankets and sand buckets, "NA" should be filled in.)

8. Maintenance Result

If the maintenance procedures for this inspection cannot be fully completed in accordance with the guidelines in this Code and attained a satisfactory result, it should not be treated as "PASS". A cross by using two straight lines to join the opposite corners in the square for "FAIL" should be marked, e.g.  means fail. Particulars of defects must be listed in Part 3 of the relevant Certificate of Fire Service Installations and Equipment (F.S. 251).

Remarks:

Other than Fire Services licensing requirement or Fire Services requirement for new buildings, if the portable equipment is a new one, which can be readily used without assembly or filling of extinguishing media, and its year of manufacture shown on the body does not exceed one year, a Certificate of Fire Service Installations and Equipment (F.S. 251) is not required. The relevant purchase receipt should be retained for future identification. In case the year of manufacture of the portable equipment exceeds 12 months (i.e. 1 year) or the extinguisher requires assembly or refilling, then the portable equipment should be inspected by a registered fire service installation contractor and a Certificate of Fire Service Installations and Equipment (F.S. 251) be issued to prove its function.

2.21 Pressurization of staircase

(i) Acceptance Testing

1. Where interaction with other systems is part of the designed operational mode, all such systems shall be correctly functioning before a final Fire Services inspection takes place.

2. 'Completion' shall include all necessary permanent labels, instruction plaques, fully detailed operating and maintenance manuals and diagrams, record 'as-built' drawings, etc.
3. Ensure tests required under sub-paragraph B.4 of paragraph 5.21 of the Code of Practice for Minimum Fire Service Installations and Equipment are carried out, recorded and record certified.
4. All systems are to be completed and tested and the designer is to satisfy himself that they are functioning correctly before the final full test and demonstration takes place with the Fire Services Inspecting Officers in attendance. A full set of completed checklists according to APPENDIX 6 and test and functional operation check records (see para. 8 hereof) shall be submitted with the request for the attendance of the Fire Services Inspecting Officers. Accompanying the checklists and records shall be a certificate signed by the designer on behalf of the design company or organization confirming or otherwise that he is satisfied that the installations are operating in accordance with his design and the requirements of the Fire Services Department.
5. Acceptance tests shall be carried out in accordance with British Standard 5588: Part 4 and the checklist. It is necessary for the designer to be present at the tests.
6. It is preferable that apart from the checklist, the format/method of the required operational and functional test be agreed with Fire Services Department before any such work commences.
7. Except for simple devices such as pitot-static tubes, inclined manometers, U gauges and the like all instruments, meters, etc. used for testing purposes shall:—
  - a. be provided in duplicate;
  - b. have a manufacturer's claimed accuracy of not more than plus or minus two percent of range;
  - c. be manufactured to an appropriate British Standard or recognized equivalent international or national standard where appropriate and available; and
  - d. have been calibrated by a recognized testing or calibration laboratory not more than 3 months prior to the date of test. The calibration certificate provided by the laboratory shall be available during the test.
8. Full and complete records are to be taken of all the tests and the results thereof including not less than:—
  - a. records of pressure testing during construction—see sub-paragraph B.4 of paragraph 5.21 of the Code of Practice for Minimum Fire Service Installations and Equipment;
  - b. make, serial no., type and owner of all instruments used, with a copy of the calibration certificates;
  - c. actual measurements taken;
  - d. corrected measurement from (c) above;
  - e. resulting air flows;
  - f. make, serial no., type and use of every device checked;
  - g. date and time of test;
  - h. signature of operator/tester or supervisor and any witness for each test; and
  - i. signature of acceptance of and by the designer.

**(ii) Maintenance**

1. For dedicated systems that only operate in emergency, they should be actuated by the owner or his agent at an interval of not more than three months, and checked to ensure that all functions and sequences are operating correctly. (See para. 3 below)
2. For dual purpose systems that operate continuously at a low level and at an increased level in emergency, they should be actuated into emergency mode by the owner or his agent at not more than six monthly intervals and checked to ensure that all emergency functions sequence

- and operate correctly. (See para. 3 below)
3. Periodic actuation should include, at least, the following actions: —
    - a. activate system by manual switch;
    - b. check that indicator lights give correct signals;
    - c. inspect staircase to ensure all doors are closed especially if magnetically held doors are utilized;
    - d. full inspection of fan rooms including:—
      - (i) fresh air inlet to be clear of debris and area in front to be free of obstruction;
      - (ii) filters (if provided) correctly in place and not at end of useful life;
      - (iii) to check any flexible connections for deterioration;
      - (iv) motor operating satisfactorily (not overheating, etc.);
      - (v) belt drive with correct belt tension and alignment or other type of drive functioning correctly;
      - (vi) fan bearings satisfactory;
      - (vii) electrical equipment satisfactory (no contactor hum, etc.);
      - (viii) record motor currents on each phase;
      - (ix) no significant air leaks;
      - (x) to check operation of pressure relief or fan by-pass dampers (and indirectly, pressure sensor) by opening and closing staircase entry door(s);
      - (xi) to check plant room for free of debris, stored materials, etc.; and
      - (xii) to check fan room entry door self closers;
    - e. throughout the staircase, a check should be conducted to ensure that air is discharging from all outlets and that pressure sensor is clean and free from obstruction;
    - f. to deactivate the manual switch and restore automatic mode;
    - g. to record actions progressively, and to complete and sign record logs.
  4. In addition to the foregoing, at intervals not exceeding 12 months, the system shall be actuated and a full test shall be carried out as described under Section 2.21(i) hereof, by a registered fire service installation contractor and a Certificate of Fire Service Installations and Equipment (F.S. 251) shall be sent to the Director of Fire Services; and
  5. A record log should be maintained by the owner or his agent for each and all systems providing a complete record of the actions carried out under para 1 to 4 hereof and the results thereof under signature of the supervisor and witness. Records should be retained for a period of at least seven years and shall be made available at any reasonable time at the request of the Director of Fire Services.

#### 2.22 Ring main system with fixed pump(s)

##### (i) Acceptance Testing

The system shall be tested to demonstrate its satisfactory performance including tests on the operation of the pumps, and on the water flow rate and working pressure of the street hydrants etc., and such other tests and inspections as may be prescribed by the Director of Fire Services on account of specific features of the system.

##### (ii) Maintenance

The installation shall be maintained in efficient working order at all times and shall be inspected by a registered fire service installation contractor at least once in every 12 months.

The fixed pump should be tested by the owner or his agent monthly on both the automatic and manual start.

The system should be examined to ensure that pipework and hydrant outlets are in good order.

### 2.23 Smoke extraction systems

Where hot smoke test is required, the followings shall be observed: —

- a. Salient points for the test: —
  - (i) The temperature of simulated hot air plume should be maintained at about 10 °C below the temperature rating of the ceiling sprinklers to avoid any unwanted actuation of sprinklers or damage to building structures and finishes;
  - (ii) The size of the test fire should be at least 1 MW or of such size as agreed by the Director of Fire Services;
  - (iii) Non-contaminating industrial grade methylated spirit may be used subject to the agreement of the Director of Fire Services;
  - (iv) Non-toxic oil based smoke produced by smoke generator may be used subject to the agreement of the Director of Fire Services;
  - (v) The test will be conducted with reference to the Australian Standard AS 4391-1999 or other equivalent international standards.
- b. Safety measures to be observed during the Hot Smoke Test: —
  - (i) Adequate safety measures should be provided to prevent any possible spread of fire during the test;
  - (ii) Adequate fire extinguishers should be provided at scene;
  - (iii) The standing-by of a fire appliance may be required if considered necessary.
- c. The smoke extraction system will be considered acceptable if the following points are complied with during the hot smoke test:—
  - (i) The designed smoke clear height should be maintained;
  - (ii) The low level fresh air make-up and the high level air extract should be formed in such a pattern that the smoke flow paths shall have a “scouring” effect in all areas within the smoke compartment. The make-up fresh air should not have any impact on the stability of the smoke layer;
  - (iii) The smoke extraction system should actuate promptly in response to a fire alarm signal;
  - (iv) No significant disperse of smoke should occur at adjoining smoke compartment(s);
  - (v) No deflection exceeding the design limit should be observed at hanging smoke curtains;
  - (vi) No significant smoke should be built up in ‘stagnant corners’ beneath the smoke layer;
  - (vii) No smoke should re-enter into the building through building openings or fresh air intake louvres.

### A. Dynamic smoke extraction system

#### (i) Acceptance Testing

1. Where interaction with other systems is part of the designed operational mode, all such systems shall be correctly functioning before a final Fire Services inspection takes place.
2. ‘Completion’ shall include all necessary permanent labels, instruction plaques, fully detailed operating and maintenance manuals and diagrams, record ‘as-built’ drawings, etc.
3. Ensure tests required under sub-paragraph B.17 of paragraph 5.23 of the Code of Practice for Minimum Fire Service Installations and Equipment are carried out, recorded and record certified.
4. All systems are to be completed and tested and the designer is to satisfy himself that they are functioning correctly before the final full test and demonstration takes place with the Fire Services Inspecting Officers in attendance. A full set of test and functional operation check

records (see para. 7 hereof) shall be submitted with the request for the attendance of the Fire Services Inspecting Officers. Accompanying the records shall be a certificate signed by the designer on behalf of the design company or organization confirming or otherwise that he is satisfied that the installations are operating in accordance with his design and the requirements of the Fire Services Department.

5. The format/method/apparatus of the required operational and functional tests (including hot smoke test) shall be agreed with Fire Services Department before any such tests commence.
6. Except for simple devices such as pitot-static tubes, inclined manometers, U gauges and the like, all instruments, meters, etc. used for testing purposes shall:—
  - a. be provided in duplicate;
  - b. have a manufacturer's claimed accuracy of not more than plus or minus two percent of range;
  - c. be manufactured to an appropriate British Standard or recognized equivalent international or national standard where appropriate and available; and
  - d. have been calibrated by a recognized testing or calibration laboratory not more than 3 months prior to the date of test. The calibration certificate provided by the laboratory shall be available during the test.
7. Full and complete records are to be taken of all tests and the results thereof including not less than:—
  - a. records of pressure testing during construction— see sub-paragraph B.17 of paragraph 5.23 of the Code of Practice for Minimum Fire Service Installations and Equipment;
  - b. make, serial no., type and owner of all instruments used, with a copy of the calibration certificates;
  - c. actual measurements taken;
  - d. corrected measurement from (c) above;
  - e. resulting air flows;
  - f. make, serial no., type and use of every device checked;
  - g. date and time of test;
  - h. signature of operator/tester or supervisor and any witness for each test; and
  - i. signature of acceptance of and by designer.

**(ii) Maintenance**

1. For dedicated systems that only operate in emergency, they should be actuated by the owner or his agent at an interval of not more than three months, and checked to ensure that all functions and sequences are operating correctly.
2. For dual purpose systems that operate continuously at a low level and at an increased level in emergency, they should be actuated into smoke extraction mode by the owner or his agent at an interval of not more than six months, and checked as in para. 1 above.
3. Where systems are mixed types the shorter intervals should apply.
4. In addition to the foregoing, at intervals not exceeding 12 months the systems shall be actuated and a full test shall be carried out as described in Section 2.23 (A) (i) hereof, by a registered fire service installation contractor and a Certificate of Fire Service Installations and Equipment (F.S. 251) shall be sent to the Director of Fire Services.
5. The owner or his agent should ensure that all routine oiling, greasing, etc. is carried out from time to time to ensure reliable operation.
6. Any fire/smoke dampers installed should be maintained regularly by the owner or his agent.
7. A record log should be maintained by the owner or his agent for all systems, providing a complete record of the actions carried out under para. 1 to 6 hereof and the results

thereof under signature of the supervisor and witness.

**B. Static smoke extraction system**

**(i) Acceptance Testing**

1. On completion of the installation the whole system shall be inspected by a registered fire service installation contractor. For installations with permanent barriers and/or exhaust openings, it shall be ensured that all barriers and openings are properly provided and all labels are supplied and fixed.
2. For systems without permanent fixed barriers and openings, all devices shall be checked in the non-operated positions; the actuation system shall then be operated and all devices checked to ensure they have operated correctly.
3. All components shall be reset to the non-operated position and then with the electrical power source removed. All devices shall again be checked to ensure that they have all correctly performed the 'fail safe' function, i.e. all in their fire positions.
4. Ensure all labels and instructions are provided.

**(ii) Maintenance**

1. The system shall be inspected annually by a registered fire service installation contractor to ensure that they are in efficient working order.
2. The inspections shall include all actuation, checking of notices, etc. as described under Section 2.23 (B)(i) hereof.

**2.24 Sprinkler system**

**(i) Acceptance Testing**

The system should be tested in accordance with the Loss Prevention Council Rules for Automatic Sprinkler Installations (with suitable modifications pertinent to Hong Kong), or other standards and requirements as may be prescribed by the Director of Fire Services on account of the specific features of the system.

**(ii) Maintenance**

The installation shall be maintained in efficient working order at all times and shall be inspected by a registered fire service installation contractor at least once in every 12 months.

**2.25 Street fire hydrant system**

**(i) Acceptance Testing**

The hydrant shall be of an accepted standard pattern and, when tested in accordance with provision of British Standard 1042 with one 65 mm outlet working, shall be capable of delivering not less than 2 000 litres per minute (33.3 l/sec.) with a minimum running pressure of 170 kPa at the outlet.

The minimum output and pressure at above paragraph should be made available from the 65 mm outlets of a system delivering at the same time, i.e. a total output of not less than 4 000 litres per minute (66.7 l/sec.).

The system shall be tested in accordance with the checklist laid down at APPENDIX 7.

**(ii) Maintenance**

The installation shall be maintained in efficient working order at all times and shall be inspected by a registered fire service installation contractor at least once in every 12 months.

**2.26 Supply tanks**

**(i) Acceptance Testing**

No specific test is required other than visual inspection for the supply tank and measurement of its effective storage capacity for compliance with the requirements of the Director of Fire

Services.

**(ii) Maintenance**

The supply tank should be maintained in full storage capacity by the owner or his agent at all times and be checked for leakage periodically.

**2.27 Ventilation/air conditioning control system**

**(i) Acceptance Testing**

The override control of the ventilation/air conditioning control system shall be tested to ensure satisfactory operation at alarm condition to the satisfaction of the Director of Fire Services.

**(ii) Maintenance**

The installation shall be maintained in efficient working order at all times and shall be inspected by a registered fire service installation contractor at least once in every 12 months.

The operation of this override control system should be tested at least once every six months, and the results entered in a log book by the owner or his agent. This log book should be kept in the premises and be available for inspection by the Director of Fire Services as and when required.

**2.28 Water mist system**

**(i) Acceptance Testing**

The system shall be tested in accordance with all the technical requirements as stipulated in NFPA 750 on Water Mist Fire Protection Systems, and other requirements as may be prescribed by the Director of Fire Services on account of the specific features of the system.

**(ii) Maintenance**

The installation shall be maintained in efficient working order at all times and shall be inspected by a registered fire service installation contractor at least once in every 12 months.

Any alteration to, repair or maintenance on the water mist system after initial installation shall also be endorsed by a qualified person, who should be a registered professional engineer under Cap. 409 in the discipline of building services, fire or mechanical engineering, or one with qualifications acceptable to the Director of Fire Services, e.g. the system manufacturer.

All installation, repair and maintenance work shall be carried out and certified by a registered fire service installation contractor.

**2.29 Water spray system**

**(i) Acceptance Testing**

The system shall be tested in accordance with all the technical requirements as stipulated in NFPA 15 for Water Spray Fixed Systems for Fire Protection, and other requirements as may be prescribed by the Director of Fire Services on account of the specific features of the system.

**(ii) Maintenance**

The installation shall be maintained in efficient working order at all times and shall be inspected by a registered fire service installation contractor at least once in every 12 months.

**2.30 Water supply**

**(i) Acceptance Testing**

The water supply for fire service systems shall be checked for permanent connection at single or dual end feed. Transfer pump, if installed, shall be tested for efficient operation.

**(ii) Maintenance**

The water supply piping system should be checked for leakage by the owner or his agent

periodically. The transfer pump shall be maintained in efficient working order at all times and be inspected by a registered fire service installation contractor at least once in every 12 months.

### Part III MISCELLANEOUS

- 3.1 This Code deals only with the inspection, testing and maintenance of fire service installations and equipment after the same have been provided for a building. The general requirements as to what installations and equipment are to be provided in buildings are dealt with in another Code called the Code of Practice for Minimum Fire Service Installations and Equipment published by the Director of Fire Services.
- 3.2 For the avoidance of doubt it is hereby declared that the Director of Fire Services, in his absolute discretion, may, in any particular case, vary any of the requirements of this Code and in particular may require different inspections or tests in regard to any installation or equipment other than the inspections or tests indicated in this Code, either in addition to or in substitution of the inspections and tests so indicated.



## LIST OF APPENDICES

APPENDIX 1	Checklist for Actuating Devices and Operation of Fire Shutter	17-18
APPENDIX 2	Checklist for CO <sub>2</sub> /Clean Agent Extinguishing System	19-23
APPENDIX 3	Checklist for Emergency Generator Installation	24-28
APPENDIX 4	Checklist for Fire Detection and Fire Alarm System	29-50
APPENDIX 5	Checklist for Fire Hydrant and Hose Reel Installation	51-62
APPENDIX 6	Checklist for Staircase Pressurization System	63-69
APPENDIX 7	Checklist for Street Fire Hydrant System	70-75
APPENDIX 8	Minimum Fire Resisting Cable Requirements for Fire Service Installations	76-77
APPENDIX 9	Shutdown of Fire Service Installations for Inspection, Maintenance, Modification or Repair	78-83
APPENDIX 10	Statutory Requirements for Maintenance, Inspection and Repair of FSI and Examination, Testing and Certification of Gas Cylinders Used as FSI	84
APPENDIX 11	Notes on Fire Extinguishers, Fire Blankets and Sand Buckets (Suitability and Maintenance)	85-97

## APPENDIX I

## Checklist for Actuating Devices and Operation of Fire Shutter

## I. REFERENCE

Project .....	FSD Ref. ....
Address .....	Location .....
LPC Ref. ....	Maker's Name .....

## II. TYPE

Single Steel Rolling Shutter	[ ]
Double Steel Rolling Shutter	[ ]
Push-up Type with Lifting Handle	[ ]
Sliding Shutter	[ ]
With Mechanical Gearing	[ ]

## III. INSTALLATION

	Yes	No	Remarks
3.1 Where automatic self-closing devices are fitted, do they cause no interference to the manual opening and closing of the shutter?	[ ]	[ ]	.....
3.2 Where smoke detectors are provided for the actuation of the shutter, are they fitted to both sides of the wall opening?	[ ]	[ ]	.....
3.3 Are smoke detectors installed as far as practicable to the provisions of the BS 5839-1:2002+A2:2008?	[ ]	[ ]	.....
3.4 Is permanent nameplate with adequate information provided?	[ ]	[ ]	.....
3.5 Are manual controls provided to both sides of the wall opening?	[ ]	[ ]	.....

## IV. SHUTTER OPERATION

4.1 Does the automatic actuation device function satisfactorily?	[ ]	[ ]	.....
4.2 Is secondary source of electricity supply provided?	[ ]	[ ]	.....
4.3 Is the descending speed* of the shutter acceptable?	[ ]	[ ]	.....

\* Descending time shall be within 15-60 seconds for shutters in openings in excess of 2.5 m in height; not faster than 8 seconds for other shutters in openings of height within 2.5 m and that the bottom rail of the shutter shall reach the mid-height in not less than half the total descending time of the shutter.

V. *GENERAL COMMENTS & REMARKS*

---

---

---

---

---

Test witnessed by:-

..... (Signature) ..... (Signature)

..... (Name in block letters) ..... (Name in block letters)  
FSI Contractor's Representative Fire Services Inspecting Officer

Date ..... Date .....

APPENDIX 2

**Checklist for CO<sub>2</sub>/Clean Agent Extinguishing System**

I. REFERENCE

Project..... FSD Ref. ....  
 Address ..... Location/Room .....

Working/Design Drawing Ref. .... Yes No N/A  
 Is drawing enclosed? [ ] [ ] [ ]  
 Approved Computer Program Ref. ....  
 Is program enclosed? [ ] [ ] [ ]  
 Is catalogue enclosed? [ ] [ ] [ ]  
 Is certification for pneumatic test to pipings enclosed? [ ] [ ] [ ]

II. TYPE OF SYSTEM

			CO <sub>2</sub>	FM200	Others*
			[ ]	[ ]	[ ]
Total Flooding	[ ] Local Application	[ ]			<i>*Please specify</i>
Modular	[ ] Cylinder	[ ]			
Pre-engineered	[ ] Engineered	[ ]			
High Pressure	[ ] Low Pressure	[ ]			
Single Hazard	[ ] Multiple Hazard	[ ]			
Primary Bank Only	[ ] With Reserve Bank	[ ]			

III. PROTECTED AREA

		Yes	No	Remarks		
3.1	Does occupancy tally with approved building plans?	[ ]	[ ]	.....		
3.2	Does compartmentation of protected premises tally with approved building plans?	[ ]	[ ]	.....		
3.3	Does general layout tally with FSI drawings?	[ ]	[ ]	.....		
3.4	Are openings properly sealed or closable automatically during/before agent discharge?	[ ]	[ ]	.....		
3.5	Are warning/instruction signs provided at entrance to; and in the case of normally occupied premises, inside the protected area?	[ ]	[ ]	.....		
3.6	Does the following components:—					
		Tally with drawings?		If not, whether the as-fitted location/position acceptable?		
		Yes	No	Yes	No	Remarks
3.6.1	Audio Alarm—Bell/Buzzer etc.	[ ]	[ ]	[ ]	[ ]	.....
3.6.2	Visual Alarm—Light/Strobe etc.	[ ]	[ ]	[ ]	[ ]	.....
3.6.3	Detector	[ ]	[ ]	[ ]	[ ]	.....
3.6.4	Manual Release	[ ]	[ ]	[ ]	[ ]	.....

	Tally with drawings?		If not, whether the as-fitted location/position acceptable?		Remarks
	Yes	No	Yes	No	
3.6.5 Piping	[ ]	[ ]	[ ]	[ ]	.....
3.6.6 Nozzles	[ ]	[ ]	[ ]	[ ]	.....
3.6.7 Agent Container	[ ]	[ ]	[ ]	[ ]	.....
3.6.8 Control/Indication Panel	[ ]	[ ]	[ ]	[ ]	.....
3.6.9 Ignition/Fuel Source Shut Down Device	[ ]	[ ]	[ ]	[ ]	.....
3.6.10 Other Mechanical/Electrical/Pneumatic Operating Device	[ ]	[ ]	[ ]	[ ]	.....

IV. THE SYSTEM (STATIC CHECK)

	Yes	No	Remarks
4.1 Are system components approved/listed?	[ ]	[ ]	.....
4.1.1 Actuating Solenoid	[ ]	[ ]	.....
4.1.2 Cylinder Valve Assembly	[ ]	[ ]	.....
4.1.3 Cylinder/Agent Container	[ ]	[ ]	.....
4.1.4 Flexible Hose	[ ]	[ ]	.....
4.1.5 Distributor/Selector Valve	[ ]	[ ]	.....
4.1.6 Pilot Cylinder	[ ]	[ ]	.....
4.1.7 Alarm Bell (for Normal Application)	[ ]	[ ]	.....
4.1.8 Siren/Yodalarm	[ ]	[ ]	.....
4.1.9 Control/Indication Panel	[ ]	[ ]	.....
4.1.10 Remote Manual Release Unit	[ ]	[ ]	.....
4.1.11 Detector	[ ]	[ ]	.....
4.1.12 Discharge Nozzle	[ ]	[ ]	.....
4.2 Is permanent nameplate with adequate information provided to:—			
4.2.1 CO <sub>2</sub> Container?	[ ]	[ ]	.....
4.2.2 FM200 Container?	[ ]	[ ]	.....
4.2.3 NAFSIII Container?	[ ]	[ ]	.....
4.3 Is reliable means of indication provided for the determination of pressure in FM200/NAFSIII container?	[ ]	[ ]	.....
4.4 Does the means of indication account for variation of container pressure with temperature?	[ ]	[ ]	.....
4.5 Is agent of sufficient quantity provided?	[ ]	[ ]	.....
4.6 Is cylinder/container properly mounted/secured?	[ ]	[ ]	.....
4.7 Are markings on nozzles showing make, type and orifice size readily discernible?	[ ]	[ ]	.....
4.8 Are pipings properly installed and secured in accordance with approved guide?	[ ]	[ ]	.....
4.9 Are pipings properly earthed?	[ ]	[ ]	.....

		Yes	No	Remarks
4.10	Are pipings suitably protected against mechanical, chemical, vibration or other damage?	[ ]	[ ]	.....
4.11	Are pipings of the approved type provided? (Please indicate the type used):—	[ ]	[ ]	.....
4.11.1	For 25-bar or 42-bar system:—			
4.11.1.1	BS 3601 Seamless Schedule 80	[ ]		
4.11.1.2	ASTM A53	[ ]		
4.11.1.3	ASTM A 106	[ ]		
4.11.1.4	JIS 3454	[ ]		
4.11.2	For 25-bar system only:—			
4.11.2.1	BS 1387 Heavy Grade Butt Welded (Up to and including 50 mm nominal pipe size)	[ ]		
4.11.2.2	BS 3601 Seamless Schedule 40 (Up to and including 100 mm nominal pipe size)	[ ]		
4.12	Are jointings of approved type provided? (Please indicate the type employed):—	[ ]	[ ]	.....
	Screwed Joints	[ ]		
	Welded Joints	[ ]		
	Others (Please state)	[ ]		
	.....			
	.....			
4.13	Is electrical apparatus intrinsically safe or of flame-proof type? (For application in explosive atmosphere only)			
4.13.1	Detector	[ ]	[ ]	.....
4.13.2	Fire Alarm Bell/Sounder	[ ]	[ ]	.....
4.13.3	Opening/Closing device will not generate sparks	[ ]	[ ]	.....
4.13.4	Ventilation shut down device will not generate sparks	[ ]	[ ]	.....

V. DETECTION, ACTUATION & CONTROL SYSTEM (STATIC CHECK)

5.1	Is the correct type of detector provided? (Please indicate the type employed):— Heat [ ] Smoke [ ]	[ ]	[ ]	.....
5.2	Is operating alarm/indicator provided? (Please indicate the type provided):— Alarm [ ] Indication [ ] Both [ ] Audio [ ] Visual [ ] Olfactory [ ]	[ ]	[ ]	.....
5.3	Do electrical sources i.e. AC & DC provide adequate source of energy for:—			
5.3.1	Detection?	[ ]	[ ]	.....
5.3.2	Operating device?	[ ]	[ ]	.....

	Yes	No	Remarks
5.4 Is manual control suitably protected against mechanical, weather or environmental damage?	[ ]	[ ]	.....
5.5 Is manual control for actuation easily accessible at all times?	[ ]	[ ]	.....
<b>VI. FUNCTIONAL TEST (DYNAMIC TEST)</b>			
6.1 Does detector operate satisfactorily?	[ ]	[ ]	.....
6.2 If cross-zoning employed, is the zoning of detectors satisfactorily arranged?	[ ]	[ ]	.....
6.3 Does operating alarm/indication function properly?	[ ]	[ ]	.....
6.4 Does actuating solenoid operate satisfactorily?	[ ]	[ ]	.....
6.5 Does selector/distributor valve operate properly?	[ ]	[ ]	.....
6.6 Does the manual control require a force of not more than 178 newtons to secure operation?	[ ]	[ ]	.....
6.7 Does the manual control require a movement of not more than 356 mm to secure operation?	[ ]	[ ]	.....
6.8 Is the shut-down of ventilation system satisfactorily accomplished?	[ ]	[ ]	.....
6.9 If time delay of not more than 30 seconds is incorporated, does it function properly?	[ ]	[ ]	.....
<b>VII. PRACTICAL DISCHARGE TEST (DYNAMIC TEST) (IF REQUIRED)</b>			
By Designed Agent	[ ]		
By Approved Substitute	[ ]		
7.1 Does agent discharge time within the limit specified by FSD?	[ ]	[ ]	.....
7.2 Are pipings securely installed to prevent pipe displacement or hazardous movement during discharge?	[ ]	[ ]	.....
7.3 Is mechanical tightness of pipings and associated equipment in order?	[ ]	[ ]	.....
<b>VIII. REINSTATEMENT OF SYSTEM AFTER DISCHARGE (STATIC CHECK)</b>			
8.1 Is replacement cylinder/container of the correct type with sufficient pressure and content provided?	[ ]	[ ]	.....
8.2 Is cylinder/container properly mounted?	[ ]	[ ]	.....
8.3 Is cylinder/container properly connected?	[ ]	[ ]	.....
8.4 Is control/indication panel properly reset?	[ ]	[ ]	.....
8.5 Is ETL properly replaced/reinstated?	[ ]	[ ]	.....
8.6 Is actuating solenoid properly linked/connected?	[ ]	[ ]	.....

IX. GENERAL COMMENTS & REMARKS

---



---



---



---



---



---

Test witnessed by:—

..... (Signature)

..... (Signature)

..... (Name in block letters)  
FSI Contractor's Representative

..... (Name in block letters)  
Fire Services Inspecting Officer

Date .....

Date .....



APPENDIX 3

Checklist for Emergency Generator Installation

I. Reference

Project: ..... FSD Ref.: .....  
 Address: .....

II. Installations and Equipment Connected (for record purpose)

Name of buildings  
 being protected: .....

	Peak Starting Current (I <sub>L</sub> )	Rated Input Power	Starting Method
(A) Fire service installation			Remarks: D.O.L. Star-delta Auto-tx. or others
i. Fixed fire pump	No. × A	No. × kW	
ii. Intermediate booster pump	No. × A	No. × kW	
iii. Sprinkler pump	No. × A	No. × kW	
iv. Fireman's lift	No. × A	No. × kW	
v. Fire detection system	No. × A	No. × kW	
vi. Smoke extraction system	No. × A	No. × kW	
vii. Staircase pressurization	No. × A	No. × kW	
viii. Exit sign/emergency lighting	No. × A	No. × kW	
ix. Others: .....			
(B) Other equipment (please specify)			
.....	A	kW	
.....	A	kW	
.....	A	kW	
.....	A	kW	
.....	A	kW	
Estimated maximum simultaneous starting and running load		kW/ kVA	

III. Emergency Generator Set Details

	<u>Alternator</u>	<u>Prime Mover</u>
3.1 Make	.....	.....
3.2 Model	.....	.....
3.3 Serial No.	.....	.....
3.4 Rated Capacity	Power ..... kVA Current ..... A	Voltage: 380/220 Power factor ..... Power ..... kW Speed: ..... rpm Frequency ..... Hz

**IV. Fuel**

- 4.1 Type:  Diesel  Other (please specify) .....
- 4.2 Type of tank:  Built-in  Separate
- 4.3 Separate fuel tank room is provided  Yes  No
- 4.4 Capacity of service tank: ..... litres Capacity of main fuel tank:..... litres
- 4.5 a. Fuel consumption ..... litres/hour rate at full load:
- b. Fuel consumption curve of generator is attached  Yes  No
- c. Time allowed for max. fuel consumption at full load ..... hours
- d. Fuel storage is sufficient for 6 hrs. generator running to support fire service installations  Yes  No
- 4.6 Fuel tank room has been inspected and approved by Dangerous Goods Division. (N.B.: Supporting document is attached)  Yes  No  N/A
- 4.7 Surveyor report for fuel tank has been obtained as required by Dangerous Goods Division.  Yes  No  N/A
- 4.8 DG license for fuel tank room holding more than 2 500 litres diesel has been obtained. (N.B.: Supporting document is attached)  Yes  No  N/A

Remarks

**V. Visual Inspection**

- 5.1 Adequate space (not less than 600 mm) is provided all round emergency generator for maintenance/cleaning.  Yes  No  N/A
- 5.2 Air supply and discharge ductworks (if any) are provided free from obstruction.  Yes  No  N/A
- 5.3 Air supply and discharge ductworks running in compartment other than emergency generator room are enclosed with proper fire resisting material.  Yes  No  N/A
- 5.4 Service fuel tank in generator room is made of 3 mm steel construction and of capacity less than 500 litres.  Yes  No  N/A
- 5.5 Generator built-in fuel tank is not greater than 500 litres.  Yes  No  N/A
- 5.6 Fuel tank is electrically earthed.  Yes  No  N/A

	Yes	No	N/A	Remarks
5.7 A baffle wall of brick-work construction or of 9 mm metal sheet is provided between the side of service tank (if installed) and generator, serving as a screen wall between the two.	[ ]	[ ]	[ ]	.....
5.8 Fuel refilling pump is connected to essential power supply.	[ ]	[ ]	[ ]	.....
5.9 A shut off valve is provided on the supply pipe from fuel tank to the service tank of generator.	[ ]	[ ]	[ ]	.....
5.10 Capacity of battery is capable of starting the generator 4 times consecutively and calculation sheet is enclosed. (Capacity: ..... Ah)	[ ]	[ ]	[ ]	.....
5.11 The batteries are kept in fully charged condition and the trickle charge is operating.	[ ]	[ ]	[ ]	.....
5.12 Inside emergency generator room,				
5.12.1 door sill of sufficient height is provided to contain the total fuel contents of the service tank (if installed), fuel tank and sump of the generator;	[ ]	[ ]	[ ]	.....
5.12.2 detailed operation instructions are displayed; and	[ ]	[ ]	[ ]	.....
5.12.3 a log book is provided.	[ ]	[ ]	[ ]	.....
5.13 Integrity of the fire resisting construction of generator room and the door is intact.	[ ]	[ ]	[ ]	.....
5.14 The notices "EMERGENCY GENERATOR" (應急發電機) and "NO SMOKING" (不准吸煙) in 120 mm English and Chinese characters are provided at the entrance to the emergency generator room.	[ ]	[ ]	[ ]	.....
<b>VI. Functional Testing</b>				
6.1 All testing are carried out with the generator room doors kept closed.	[ ]	[ ]	[ ]	.....
6.2 The manual starting facilities of the emergency generator can operate satisfactorily.	[ ]	[ ]	[ ]	.....
6.3 Upon failure of normal electricity supply, emergency generator:—	[ ]	[ ]	[ ]	.....
6.3.1 automatically starts when the duration of power failure exceeds 1 second; and	[ ]	[ ]	[ ]	.....
6.3.2 transfers to FS loads within 15 seconds.	[ ]	[ ]	[ ]	.....
6.4 Emergency generator is capable of restarting upon failure of first attempt in starting.	[ ]	[ ]	[ ]	.....

	Yes	No	N/A	Remarks
6.5 Audible and visual alarms are given locally, and at fire control main panel when the generator starting sequence is locked out due to starting failure.	[ ]	[ ]	[ ]	.....
6.6 After one hour of running test, all instruments, safety devices, etc. indicate "normal" condition.	[ ]	[ ]	[ ]	.....
6.7 The generator set will continue to run after a pre-determined time recommended by manufacturer unless it is stopped manually if the normal power supply has resumed.	[ ]	[ ]	[ ]	.....
6.8 Warning signal is given locally and at fire control main panel when manual/auto selector switch turn to manual position. (N.B. such provision is strongly recommended)	[ ]	[ ]	[ ]	.....
6.9 Remote control valve on supply pipe to the service tank is in good working order.	[ ]	[ ]	[ ]	.....
6.10 All moving parts are effectively and rigidly guarded for safety.	[ ]	[ ]	[ ]	.....
6.11 All hot parts are properly insulated.	[ ]	[ ]	[ ]	.....
6.12 No exhaust leak is detected inside generator room while the generator is running.	[ ]	[ ]	[ ]	.....

**VII. On Load Test**

- 7.1 All loadings as listed in item 2 were connected [ ] Yes [ ] No
- 7.2 Frequency (Hz) .....
- 7.3 Maximum starting current ( $I_{LMAX}$ )  
R: ..... A Y: ..... A B: ..... A
- 7.4 Voltage dip: ..... % Voltage recovery time: .....seconds
- 7.5 Running current ( $I_L$ )  
R: ..... A Y: ..... A B: ..... A
- 7.6 Voltage (Volts)  
R-Y: ..... Y-B: ..... B-R: .....  
R-N: ..... Y-N: ..... B-N: .....
- 7.7 Engine speed (rpm) .....
- 7.8 Duration of on-load test (hr.) .....

**VIII. General Comments & Remarks**

---



---



---



---



---

Tested by:

Signature: .....

Full Name of  
Installation Engineer: .....

Name of  
FSI Contractor: .....

Company Chop: .....

Date: .....

Witnessed by:

Signature: .....

Full Name of  
Design Engineer: .....

Name of  
Design Consultant: .....

Company Chop: .....

Date: .....

## APPENDIX 4

**Checklist for Fire Detection and Fire Alarm System****I. Reference**

Project: ..... FSD Ref.: .....  
 Address: .....  
 Type of Building:  
 Domestic/Industrial/Institutional/Godown/Commercial/Office/Composite/Hotel/Hospital/Others .....  
 ..... and with/without basement.

**II. Type of Equipment****2.1 Alarm Annunciation Panel**

2.1.1 Manufacturer/Model No.: (Main panel) .....  
 (Sub-panel/repeater panel, if any) .....

2.1.2 Type: Conventional type [ ]  
 Addressable type [ ]

**2.2 Detectors**

2.2.1 Heat detector Manufacturer/Model No.: .....  
 Type: Fixed temperature [ ]  
 Rate-of-rise temperature [ ]  
 Combination [ ]  
 Linear cable [ ]  
 Others .....

2.2.2 Smoke detector Manufacturer/Model No.: .....  
 Type: Ionization [ ]  
 Optical [ ]  
 Beam [ ]  
 Aspirating [ ]  
 Others .....

2.2.3 Flame detector Manufacturer/Model No.: .....  
 Type: Infrared [ ]  
 Ultra-violet [ ]  
 Combination [ ]  
 Others .....

2.2.4 Others Manufacturer/Model No.: .....  
 Type: .....

2.3 Manual Call Points  
 Manufacturer/Model No.: .....  
 Type: Breakglass type [ ]  
 Others .....

2.4 Alarm Sounders  
 Manufacturer/Model No.: .....  
 Type: Bell [ ]  
 Yodalarm [ ]  
 Horn [ ]  
 Siren [ ]  
 Electronic sounder [ ]  
 Others .....

2.5 Visual Fire Alarm Units  
 Manufacturer/Model No.: .....

2.6 Smoke Detector with Sounder Base  
 Manufacturer/Model No.: .....

2.7 Power Supplies  
 Mains supply: Supply voltage/Phase/Hz: .....  
 Secondary supply: Type: Emergency generator [ ]  
 Feed before main switch [ ]  
 Secondary (rechargeable) battery [ ]  
 Rating: .....Voltage ..... Amp-hour  
 Others .....

2.8 Fire Resisting Cables  
 Manufacturer/Model No.: .....

	Yes	No	N/A	Remarks	Reference BS CL
<b>III. Visual Inspection</b>					
<b>3.1 General</b>					
3.1.1					

3.1.1 The initial building plans submission is received by FSD on or after 1 September 2009. [ ] [ ] [ ] [ ] .....  

	1/2009
--	--------

	Yes	No	N/A	Remarks	Reference BS	CL
3.1.2 All individual components of the fire alarm system including detectors and the control panel are mutually compatible.	[ ]	[ ]	[ ]	.....		
3.1.3 An as-fitted zoning schedule is provided adjacent to the alarm annunciation panel.	[ ]	[ ]	[ ]	.....		
3.1.4 A log book is provided adjacent to the alarm annunciation panel.	[ ]	[ ]	[ ]	.....		
3.1.5 The building plans submission for extensions and additions involving major alterations and additions to the building is in excess of 50% by volume and is received by FSD on 1 September 2009 or later.	[ ]	[ ]	[ ]	.....		1/2009
3.2 <u>Detector</u>						
3.2.1 The detection zonings are properly labelled at the alarm annunciation panel.	[ ]	[ ]	[ ]	.....	13.2.4a)	
3.2.2 Detectors are provided in areas as indicated on approved building plans.	[ ]	[ ]	[ ]	.....		
Point type heat detector: .....				nos.		
Linear heat cable: .....				sets		
Point type smoke detector: .....				nos.		
Beam smoke detector: .....				sets		
Aspirating smoke detector: .....				sets		
Flame detector: .....				nos.		
Others: .....				nos.		



	Yes	No	N/A	Remarks	Reference	
					BS	CL
3.2.3 On the floor(s) where sleeping risk exists (e.g. hotel, hospital, hostel, etc.):						2/2009
(a) heat detector is used in kitchen and E/M plant room.	[ ]	[ ]	[ ]	.....		
(b) smoke detector is used in other areas except toilet, bathroom and staircase where sprinkler is provided.	[ ]	[ ]	[ ]	.....		
(c) sounder base is provided for smoke detector in guestrooms of hotels / guesthouses / bedrooms of student hostels except detector inside concealed space.	[ ]	[ ]	[ ]	.....		
3.2.4 Detectors are provided to basement according to the approved building plan.	[ ]	[ ]	[ ]	.....		
3.2.5 Intrinsically safe or flameproof device is used within potentially hazardous areas.	[ ]	[ ]	[ ]	.....		
3.2.6 External indicator is provided outside the doors of rooms where travel distance of the detectors inside the rooms exceeds 30 m of reach within a zone.	[ ]	[ ]	[ ]	.....	13.2.3b)	1/2009
3.2.7 Remote indicating lamps are provided for ceiling void or floor void detectors, if addressable text display in conjunction with layout plans are not provided adjacent to the control and indicating equipment.	[ ]	[ ]	[ ]	.....	13.2.4b) 13.2.5	1/2009
3.2.8 Detectors are provided for horizontal ceiling void $\geq 800$ mm high.	[ ]	[ ]	[ ]	.....	22.2d)	1/2009

	Yes	No	N/A	Remarks	Reference BS	CL
3.2.9 Clearance below detector is $\geq 500$ mm. (Not applicable for ceiling voids, floor voids, and area having no horizontal dimension greater than 1 m.)	[ ]	[ ]	[ ]	.....	22.3n)	
3.2.10 Point smoke detector is installed within ceiling height limit (general) of 10.5 m. (Note: $\leq 10\%$ of ceiling height may exceed this limit and $\leq 12.5$ m).	[ ]	[ ]	[ ]	.....	22.9 Table 3	1/2009
3.2.11 Heat detector is installed within ceiling height limit (general) of 9 m for Class A1 to BS EN 54-5 and 7.5 m for other Classes to BS EN 54-5. (Note: $\leq 10\%$ of ceiling height may exceed this limit and $\leq 10.5$ m).	[ ]	[ ]	[ ]	.....	22.9 Table 3	1/2009
3.2.12 Under flat ceiling, horizontal distance between any point and the nearest heat detector is $\leq 5.3$ m.	[ ]	[ ]	[ ]	.....	22.3a)2)	
3.2.13 Under flat ceiling, horizontal distance between any point and the nearest smoke detector is $\leq 7.5$ m.	[ ]	[ ]	[ ]	.....	22.3a)	
3.2.14 In corridors $\leq 2$ m wide, heat detectors are sited at intervals of $\leq 10.6$ m and $\leq 5.3$ m from end wall.	[ ]	[ ]	[ ]	.....	22.3a), Note 1	
3.2.15 In corridors $\leq 2$ m wide, smoke detectors are sited at intervals of $\leq 15$ m and $\leq 7.5$ m from end wall.	[ ]	[ ]	[ ]	.....	22.3a), Note 1	

	Yes	No	N/A	Remarks	Reference	
					BS	CL
3.2.16 In detector installation, ceiling obstructions > 10% overall ceiling height are treated as wall. (Note: Within horizontal voids, obstructions > 10% of the height between structural floor and structural ceiling are treated as wall regardless of the void location.)	[ ]	[ ]	[ ]	.....	22.3j), Note 8	1/2009
3.2.17 In detector installation, partitions or storage racks reaching within 300 mm of the ceiling are treated as wall.	[ ]	[ ]	[ ]	.....	22.3i)	
3.2.18 Detectors are mounted $\geq$ 1 m from any air inlet of forced ventilation system.	[ ]	[ ]	[ ]	.....	22.3m)	
3.2.19 Horizontal ceiling comprises:					22.3k)	
(a) a series of small cells (honeycomb ceiling), detector spacing is in accordance with Figure 10b) & Table 1 of BS 5839-1;	[ ]	[ ]	[ ]	.....		
(b) a number of closely spaced structural beams, detector spacing is in accordance with Figure 10c) & Table 2 of BS 5839-1.	[ ]	[ ]	[ ]	.....		
3.2.20 Detector(s) is provided under intermediate horizontal surfaces such as ducts, loading platforms and storage racks in excess of 3.5 m in width and whose undersurface is in excess of 800 mm above the floor (other than when the side of the duct or structure is in excess of 800 mm from the wall or other ducts or structure).	[ ]	[ ]	[ ]	.....	22.3o)	

		Yes	No	N/A	Remarks	Reference	
						BS	CL
3.2.21	Other than point type smoke and heat detectors, the following detectors are according to manufacturer's standard and specification.						
	(a) Aspirating smoke detectors	[ ]	[ ]	[ ]	.....		
	(b) Flame detectors	[ ]	[ ]	[ ]	.....		
	(c) Video smoke detectors	[ ]	[ ]	[ ]	.....		
	(d) Beam detectors	[ ]	[ ]	[ ]	.....		
	(e) Others, please specify: .....	[ ]	[ ]	[ ]	.....		
3.3	<u>Alarm Sounder</u>						
3.3.1	Provided in areas as indicated on FSI layout plans.						
	Alarm sounder: ..... nos.	[ ]	[ ]	[ ]	.....		
3.3.2	External fire alarm sounder is provided at the building entrance or the "Fire Service Access Point" and control and indicating equipment.					16.2.1f)	1/2009
	The sounder is clearly marked with the words "FIRE ALARM" (火警).	[ ]	[ ]	[ ]	.....		
3.3.3	One alarm sounder is provided at each hose reel point.	[ ]	[ ]	[ ]	.....	Code	
3.3.4	Each system incorporates at least two sounders and each fire compartment is provided with at least one sounder. (Note: Meaning of fire compartment is as defined in paragraph 5 of the FRC Code.)	[ ]	[ ]	[ ]	.....	16.2.1i)	1/2009

	Yes	No	N/A	Remarks	Reference	
					BS	CL
3.4 <u>Manual Call Point (MCP)</u>						
3.4.1 Provided in areas as indicated on FSI layout plans.  MCP: ..... nos. [ ] [ ] [ ] .....						
3.4.2 The zoning is at least one zone per floor. [ ] [ ] [ ] .....					13.2.2	1/2009
3.4.3 One MCP is located:					20.2c)	1/2009
(a) at hose reel point; [ ] [ ] [ ] .....						
(b) adjacent to & within 2m from storey exit (or its entrance lobby if it leads only to the storey exit); [ ] [ ] [ ] .....						
(c) adjacent to staircase final exit to open air on G/F or place of ultimate safety. [ ] [ ] [ ] .....						
3.4.4 For exit opening $\geq$ 12 m in width, two MCPs are provided within 2 m from each end of the opening before exit (or before the entrance lobby if such lobby leads only to the exit). [ ] [ ] [ ] .....					20.2c)	1/2009
3.4.5 MCP is fixed at a height of 0.9 to 1.2 m above finished floor level. [ ] [ ] [ ] [ ] .....					20.2h)	1/2009
3.4.6 MCPs are surface mounted or semi-recessed mounted as per manufacturer's design. [ ] [ ] [ ] [ ] .....					20.2i)	1/2009
3.5 <u>Visual Fire Alarm (VFA)</u>						
3.5.1 VFA is labelled "FIRE ALARM" (火警) with height of English and Chinese wordings $\geq$ 10 mm and 15 mm respectively. [ ] [ ] [ ] [ ] .....					Code	
3.5.2 Alarm signal is in form of flashing red light. [ ] [ ] [ ] [ ] .....					Code	

	Yes	No	N/A	Remarks	Reference	
					BS	CL
3.5.3 Flashing light of VFA is visible to normal eyesight in all areas required to be protected.	[ ]	[ ]	[ ]	.....	Code	
3.5.4 One VFA point is provided for each compartment and the distance between two VFA points $\leq$ 60 m.	[ ]	[ ]	[ ]	.....	Code	
3.5.5 Areas covered by VFA are in compliance with approved building plans and Design Manual: Barrier Free Access.	[ ]	[ ]	[ ]	.....	Code	
3.5.6 Design of VFA system conforms to Code of Practice and					Code CL	
(a) NFPA 72: 2010 or	[ ]	[ ]	[ ]	.....		
(b) BS 5839-1:2002+A2: 2008	[ ]	[ ]	[ ]	.....		
3.5.7 One VFA point is located near every hose reel.	[ ]	[ ]	[ ]	.....		
3.5.8 The power supply of the VFA system is from:						
(a) DC supply source with back-up supply by battery; or	[ ]	[ ]	[ ]	.....		
(b) AC supply source with secondary supply from emergency generator; or	[ ]	[ ]	[ ]	.....		
(c) AC supply source with secondary supply from the main electricity supply obtained before main supply switch.	[ ]	[ ]	[ ]	.....		

3.6	Cables, Wiring and Other Interconnections	Yes	No	N/A	Remarks	Reference	
						BS	CL
3.6.1	Cables used for:					26.2b)	1/2009
	(a) Critical signal path (panel to all field devices);						
	(b) extra low voltage supply from external power supply (charger / battery) to the system;						
	(c) final circuit providing low voltage mains supply to the system; and						
	(d) low voltage mains supply to the system (mains supply to panel / charger)						
	comply with:						
	(i) MICS cable conforming to BS EN 60702-1 & 60702-2;						
	or	[ ]	[ ]	[ ]	.....		
	(ii) Cable conforming to BS 7629; or	[ ]	[ ]	[ ]	.....		
	(iii) Cable conforming to BS 7846; or	[ ]	[ ]	[ ]	.....		
	(iv) Cable rated at 300/500 V (or greater) that provide same degree of safety to BS 7629;						
	or	[ ]	[ ]	[ ]	.....		
	(v) Fire resisting cables to other international standard accepted by FSD; or	[ ]	[ ]	[ ]	.....		
	(vi) Cables as per Remarks Section in Appendix 8 of FS CoP and accepted being exempted from requirement of fire resistance;	[ ]	[ ]	[ ]	.....		

	Yes	No	N/A	Remarks	Reference	
					BS	CL
Except for item (vi), item (i) to (v) shall also comply with:						
(vi) "Standard" fire resisting cables with PH30 classification according to BS EN 50200 and additional 30 min. survival time to Annex E of this standard; or	[ ]	[ ]	[ ]	.....	26.24)	1/2009
(viii) "Enhanced" fire resisting cables with PH120 classification according to BS 8434-2.	[ ]	[ ]	[ ]	.....	26.2e)	1/2009



	Yes	No	N/A	Remarks	Reference	
					BS	CL
3.6.2 Cables used for power supply to sounders, visual fire alarms, fire alarm devices, control modules, signalling devices, etc. comply with:					26.2b)	1/2009
(i) MICS cable conforming to BS EN 60702-1 & 60702-2; or	[ ]	[ ]	[ ]	.....		
(ii) Cable conforming to BS 7629; or	[ ]	[ ]	[ ]	.....		
(iii) Cable conforming to BS 7846; or	[ ]	[ ]	[ ]	.....		
(iv) Cable rated at 300/500 V (or greater) that provide same degree of safety to BS 7629; or	[ ]	[ ]	[ ]	.....		
(v) Fire resisting cables to other international standard accepted by FSD; or	[ ]	[ ]	[ ]	.....		
(vi) Cable conforming to BS 6387 AWX or CWZ; or	[ ]	[ ]	[ ]	.....		
(vii) Cables as per Remarks Section in Appendix 8 of FS CoP and accepted being exempted from requirement of fire resistance;	[ ]	[ ]	[ ]	.....		
Except for item (vii), item (i) to (vi) shall also comply with:						
(viii) "Standard" fire resisting cables with PH30 classification according BS EN 50200 and additional 30 min. survival time to Annex E of this standard; or	[ ]	[ ]	[ ]	.....	26.2d)	1/2009
(ix) "Enhanced" fire resisting cables with PH120 classification according to BS 8434-2.	[ ]	[ ]	[ ]	.....	26.2e)	1/2009

	Yes	No	N/A	Remarks	Reference	
					BS	CL
3.6.3 Conductors are having a cross-sectional area of $\geq 1 \text{ mm}^2$ .	[ ]	[ ]	[ ]	.....	26.2j)	
3.6.4 Cables and conductors are separated from cables of other services.	[ ]	[ ]	[ ]	.....	26.2k) 26.2l) 26.2m)	
3.6.5 Cables carrying power in excess of extra-low voltage are segregated from extra-low voltage fire alarm circuits.	[ ]	[ ]	[ ]	.....	26.2n)	
3.6.6 Colour of cables is limited to $\leq$ two sets of common colours and one of the colours is red.	[ ]	[ ]	[ ]	.....	26.2o)	
<b>3.7 Control and Indicating Equipment</b>						
3.7.1 The alarm annunciation panel is located near entrance or in fire control centre.	[ ]	[ ]	[ ]	.....		
3.7.2 Manual call point indications are given at the control and indicating panel even if addressable text information is available.	[ ]	[ ]	[ ]	.....		
3.7.3 Manual call point and detection zone indications are given at the control and indicating panel even if addressable text information is available, by one or a combination of the following:					23.2.2c) to e)	
(a) LED indicators	[ ]	[ ]	[ ]	.....		
(b) Visual display units	[ ]	[ ]	[ ]	.....		
(c) Computer graphics	[ ]	[ ]	[ ]	.....		
(d) Other suitable means (please specify .....)	[ ]	[ ]	[ ]	.....		

	Yes	No	N/A	Remarks	Reference	
					BS	CL
3.7.4 The wirings are compatible with the type of control panel as recommended by the panel manufacturer. (2-wire system/4-wire system/twisted pair/..... .....) [ ] [ ] [ ] .....						
3.7.5 Operation of alarm silent facility should:					16.2.1g)	
(a) require manual operation;	[ ]	[ ]	[ ]	.....		
(b) not cancel any visual signal;	[ ]	[ ]	[ ]	.....		
(c) if a new zone goes into alarm, sound any fire alarm sounders belonging to that alarm zone;	[ ]	[ ]	[ ]	.....		
(d) not prevent correct operation of any control;	[ ]	[ ]	[ ]	.....		
(e) not prevent transmission of alarm to alarm receiving centre.	[ ]	[ ]	[ ]	.....		
3.8 <u>Power Supplies</u>						
3.8.1 Connections to the mains supply is via an independent isolating protective device.	[ ]	[ ]	[ ]	.....	25.2a)	

	Yes	No	N/A	Remarks	Reference	
					BS	CL
3.8.2 Every isolator, switch and protective device is situated in a position inaccessible to unauthorized persons or protected against unauthorized operation and is properly labelled as appropriate:  (a) "FIRE ALARM" (火警警報); or (b) "FIRE ALARM. DO NOT SWITCH OFF" (火警警報·切勿切斷電源); or (c) "WARNING. THIS SWITCH ALSO CONTROLS THE SUPPLY TO THE FIRE ALARM SYSTEM" (警告, 此電掣同時控制火警警報系統電源).  All labels are engraved in white letter/character with a red background. The words "FIRE ALARM" (火警) with height of English and Chinese wordings ≥ 10 mm and 15 mm respectively.					25.2f) 25.2g)	1/2009
3.8.3 Circuit supplying fire alarm system is not protected by a residual current device. (unless necessary to comply with CoP for the Electricity (Wiring) Regulations)	[ ]	[ ]	[ ]	.....	25.2h)	
3.8.4 The mains power supply and the standby battery are each capable of supplying the maximum alarm load of the system.	[ ]	[ ]	[ ]	.....	25.2i) 25.3d)	

	Yes	No	N/A	Remarks	Reference BS	CL
3.8.5 Battery power supply is provided. (Voltage: ..... DC Volts: ..... Ahr: .....)	[ ]	[ ]	[ ]	.....		
3.8.6 Secondary (rechargeable) battery supplies should:					25.4	
(a) be with an automatic charger;	[ ]	[ ]	[ ]	.....		
(b) have a life of at least 4 years;	[ ]	[ ]	[ ]	.....		
(c) have date of installation labelled;	[ ]	[ ]	[ ]	.....		
(d) have battery charger capable of recharging the battery from fully discharged to fully charged within 24 hours; and	[ ]	[ ]	[ ]	.....		
(e) have capacity sufficient to maintain the system operation.	[ ]	[ ]	[ ]	.....		

**IV. Testing**

**4.1 Detectors**

4.1.1 Upon actuation of any detector in the building, the correct audio/visual warning device is initiated.	[ ]	[ ]	[ ]	.....		
4.1.2 The sensitivity of all heat/smoke/flame detectors are correctly set in full accordance with the manufacturer's recommendations.	[ ]	[ ]	[ ]	.....		
4.1.3 The zoning of detectors is correct.	[ ]	[ ]	[ ]	.....		

**4.2 Manual Call Point, Alarm Sounder and Visual Fire Alarm Installations**

4.2.1 Upon actuation of the detector, alarm is given by alarm sounder installed at the building entrance near the alarm annunciation panel.	[ ]	[ ]	[ ]	.....		
---	-----	-----	-----	-------	--	--

		Yes	No	N/A	Remarks	Reference BS	CL
4.2.2	Background noise (N) likely to persist for a period longer than 30 seconds.	[ ]	[ ]	[ ]	at.....dB(A).....	16.2.1 a)1)	
4.2.3	For domestic building, the minimum sound level of alarm sounders is measured at 3 m from the inside of the main entrance door with all doors shut off & all windows open at all flats and the result is ..... dB(A), which is:  (a) $\geq 60$ dB(A); and (b) $\geq 5$ dB(A) + ..... (background noise, N) = .....dB(A).	[ ]	[ ]	[ ]	.....	16.2.1 a)1)	
4.2.4	For non-domestic building, the minimum sound level of alarm sounders is measured at 3 m from the inside of the main entrance door with all doors shut off & all windows open at all flats and the result is ..... dB(A), which is:  (a) $\geq 65$ dB(A); and (b) $\geq 5$ dB(A) + ..... (background noise, N) = .....dB(A).	[ ]	[ ]	[ ]	.....	16.2.1 a)1)	
4.2.5	The sound level measured right below the sounder base(s) of smoke detector and 1 m above floor level with all the guestroom/bedroom windows fully opened and doors closed is $\geq 65$ dB(A) or $> 5$ dB(A) above background noise.	[ ]	[ ]	[ ]	.....		1/2009 2/2009
4.2.6	The zoning of manual call points is correct.	[ ]	[ ]	[ ]	.....	12.2.2j), Note 3	1/2009

	Yes	No	N/A	Remarks	Reference BS CL	
4.2.7 Upon actuation of any manual call point in the building, the fixed fire pump serving the corresponding block comes into operation regardless of the zoning of the manual call point.	[ ]	[ ]	[ ]	.....	Code	
4.2.8 Upon actuation of any manual call point in the building, the correct audio/visual warning device for the fire alarm and detection system is initiated.	[ ]	[ ]	[ ]	.....		
4.2.9 The delay between operation of a manual call point and the giving of an "evacuate" signal in the alarm zone does not exceed 3 seconds.	[ ]	[ ]	[ ]	.....	20.2b)	
4.2.10 All VFA flashing light is visible to normal eyesight in the required protected areas when the fire alarm system is actuated.	[ ]	[ ]	[ ]	.....	Code	
4.2.11 VFA signal is clearly distinguishable from any other non-fire services visual signals.	[ ]	[ ]	[ ]	.....		
4.3 <u>Power Supplies</u>						
4.3.1 For occupied premises, the standby battery is sufficient to maintain the system in operation for at least 24 hours, plus at least 30 min. for an "evacuate" signal in all alarm zones.	[ ]	[ ]	[ ]	.....	25.4e)1)	

		Yes	No	N/A	Remarks	Reference BS CL	
4.3.2	For unoccupied premises, the standby battery is sufficient to maintain the system in operation for at least 24 hours longer than maximum period likely to be unoccupied or for 72 hours in total, whichever is the less, after which to operate all fire alarm devices for at least 30 min.	[ ]	[ ]	[ ]	.....	25.4.e)4)	
4.3.3	In building with standby generator that serves fire alarm system, capacity is sufficient to maintain the system in operation for at least six hours, plus at least 30 min. for an “evacuate” signal in all alarm zones.	[ ]	[ ]	[ ]	.....	25.4.e)1) 25.4.e)2)	
4.3.4	The normal or standby supply is indicated by a green indicator at main indicating equipment.	[ ]	[ ]	[ ]	.....	25.3c)	
4.3.5	Each of the normal supply and the standby supply is capable of supplying the largest load under normal, fire and fault conditions.	[ ]	[ ]	[ ]	.....		
4.4	<u>Control and Indicating Equipment</u>						
4.4.1	Alarm is given from the alarm sounder installed at building external upon fire detection.	[ ]	[ ]	[ ]	.....		
4.4.2	Direct telephone link (DTL) to service provider’s Computerized Fire Alarm Transmission System (CFATS) is connected. (Please state DTL no.: ..... .....)	[ ]	[ ]	[ ]	.....		



		Yes	No	N/A	Remarks	Reference	
						BS	CL
4.4.3	Other panel function works properly:						
	(a) alarm silence/reset.	[ ]	[ ]	[ ]	.....		
	(b) battery supply on. (if applicable)	[ ]	[ ]	[ ]	.....		
	(c) power on/failure indicator.	[ ]	[ ]	[ ]	.....		
	(d) direct link failure indicator. (if applicable)	[ ]	[ ]	[ ]	.....		
	(e) zone alarm/fault indicator.	[ ]	[ ]	[ ]	.....		
4.4.4	Detector solely using as actuating devices for fire service systems such as fire shutter, VAC control, fixed installations other than water, fixed installation using water, pressurization system, and smoke extraction systems are linked to the Computerized Fire Alarm Transmission System (CFATS) via DTL. (Remark: This linking is not mandatory.)	[ ]	[ ]	[ ]	.....		
4.4.5	For addressable type alarm annunciation panel, a facility/provision is provided so that individual detector can be tested without either sounding an alarm or requiring the complete system to be disabled to prevent such an alarm.	[ ]	[ ]	[ ]	.....		

V. Documentation		Yes	No	N/A	Remarks	Reference BS CL	
5.1	The following equipment list and catalogues are provided (where applicable):						
	(a) alarm annunciation panel;	[ ]	[ ]	[ ]	.....		
	(b) repeater panels;	[ ]	[ ]	[ ]	.....		
	(c) detectors;	[ ]	[ ]	[ ]	.....		
	(d) manual call points;	[ ]	[ ]	[ ]	.....		
	(e) alarm sounders;	[ ]	[ ]	[ ]	.....		
	(f) visual fire alarm;	[ ]	[ ]	[ ]	.....		
	(g) fire resisting cables.	[ ]	[ ]	[ ]	.....		
5.2	FSD approval/listing by product certification bodies are provided for the following equipment:						1/2007
	(a) alarm annunciation panel;	[ ]	[ ]	[ ]	.....		
	(b) repeater panels;	[ ]	[ ]	[ ]	.....		
	(c) detectors;	[ ]	[ ]	[ ]	.....		
	(d) manual call points;	[ ]	[ ]	[ ]	.....		
	(e) alarm sounders;	[ ]	[ ]	[ ]	.....		
	(f) visual fire alarm with sounder.	[ ]	[ ]	[ ]	.....		
5.3	Testing certificates are provided for the fire resistant cables.	[ ]	[ ]	[ ]	.....		
5.4	Sound level measurement (including background noise) report for alarm sounders is provided.	[ ]	[ ]	[ ]	.....		
5.5	Calculation showing the required battery capacity is provided.	[ ]	[ ]	[ ]	.....		
5.6	Letter certifying the completion of the DTL to the FSCC/authorized service provider is provided.	[ ]	[ ]	[ ]	.....		

	Yes	No	N/A	Remarks	Reference	
					BS	CL
5.7 Confirmation or certification from panel manufacturer on the compatibility between the fire alarm control panel(s) and detectors is provided.	[ ]	[ ]	[ ]	.....		
5.8 As-fitted fire service installation drawings including the following are provided:						
(a) schematic diagrams of the fire alarm and detection system;	[ ]	[ ]	[ ]	.....		
(b) floor layout plans showing the location of detectors, devices, alarm annunciation panel and repeater panel(s) as applicable.	[ ]	[ ]	[ ]	.....		

Test witnessed by:

Signature: .....

Name of Responsible Engineer: .....

Name of FSI Contractor: .....

Company Chop: .....

Registration No.: RC1/..... and RC2/..... Date: .....

## APPENDIX 5

## Checklist for Fire Hydrant and Hose Reel Installation

## I. REFERENCE

Project: ..... FSD Ref.: .....

Type of Building: \*Domestic/Industrial/Godown/Others .....

Address: .....

FSI Drawing Ref. ....

The date of initial building plan submission to Building Authority .....

\*Delete whichever not applicable

	Yes	No	N/A	Remarks
II. FSI DRAWINGS AGAINST BUILDING PLANS				
FSD File Ref. ....				
2.1 Check nos. and locations of:				
2.1.1 Fire service inlets	[ ]	[ ]	[ ]	.....
2.1.2 Fire hydrants and hose reels	[ ]	[ ]	[ ]	.....
2.1.3 Fixed fire pumps	[ ]	[ ]	[ ]	.....
2.1.4 Intermediate booster pumps	[ ]	[ ]	[ ]	.....
2.1.5 Water tank and capacity	[ ]	[ ]	[ ]	.....
III. PLUMBING LINE DIAGRAM				
3.1 CHECK:				
3.1.1 Pippings are suitably connected to the fire pumps, fire hydrants, hose reels and fire service inlets.	[ ]	[ ]	[ ]	.....
3.1.2 Size of the rising mains are correct.	[ ]	[ ]	[ ]	.....
3.1.3 Size of the inter-connection header pipe(s) for fire service inlets is correct.	[ ]	[ ]	[ ]	.....
3.1.4 By-pass pipings for intermediate booster pumps.	[ ]	[ ]	[ ]	.....
3.1.5 FS appliance to be provided by FSD to test the system. (to be confirmed by FSD)	[ ]	[ ]	[ ]	.....
IV. ON SITE INSPECTION				
4.1 FIRE HYDRANT				
4.1.1 Outlets are of: Male round thread [ ] or Female instantaneous [ ]				
4.1.2 Adaptable to FSD equipment.	[ ]	[ ]	[ ]	.....
4.1.3 Individually controlled by wheel operated screw valve designed to open by counter-clockwise rotation.	[ ]	[ ]	[ ]	.....
4.1.4 The direction of opening engraved in both English and Chinese on the wheel of the valve.	[ ]	[ ]	[ ]	.....

	Yes	No	N/A	Remarks
4.1.5 Centre of coupling not less than 800 mm nor more than 1 200 mm above finished floor level.	[ ]	[ ]	[ ]	.....
4.1.6 Prominently sited [ ] or Recessed [ ]				
4.1.7 All round clearance to permit free use.	[ ]	[ ]	[ ]	.....
4.1.8 Not obstructing any door opening, or any exit route.	[ ]	[ ]	[ ]	.....
4.1.9 Not to be concealed by the leaves of an adjacent door when that door is opened.	[ ]	[ ]	[ ]	.....
4.1.10 Water supply is fed:				
By gravity [ ]				.....
From fixed fire pump [ ]				.....
4.2 HOSE REEL				
4.2.1 Hose reel drum is painted in red.	[ ]	[ ]	[ ]	.....
4.2.2 The drum is not less than 150 mm in diameter.	[ ]	[ ]	[ ]	.....
4.2.3 Internal bore of tubing is not less than 19 mm diameter.	[ ]	[ ]	[ ]	.....
4.2.4 Length of hose reel is not exceeding 30 metres in length.	[ ]	[ ]	[ ]	.....
4.2.5 Every part of the building can be reached by a nozzle.	[ ]	[ ]	[ ]	.....
4.2.6 Capable of projecting a 6-metre jet.	[ ]	[ ]	[ ]	.....
4.2.7 Orifice of nozzle is 4.5 mm.	[ ]	[ ]	[ ]	.....
4.2.8 Nozzle is fitted with simple two-way on/off valve and the valve is not spring loaded.	[ ]	[ ]	[ ]	.....
4.2.9 Control valves are of gate type or of simple two-way ball type.	[ ]	[ ]	[ ]	.....
4.2.10 Gate valves are closed by clockwise rotation.	[ ]	[ ]	[ ]	.....
4.2.11 Rising mains and associated pipework are not less than 40 mm nominal bore.	[ ]	[ ]	[ ]	.....
4.2.12 Pipes feeding individual hose reel are not less than 25 mm nominal bore.	[ ]	[ ]	[ ]	.....
4.2.13 Control valves are adjacent to the nozzles.	[ ]	[ ]	[ ]	.....
4.2.14 Nozzle and control valves are not more than 1 350 mm from the finished floor level.	[ ]	[ ]	[ ]	.....
4.2.15 Nozzle is housed in a glass-fronted cabinet secured under lock and key.	[ ]	[ ]	[ ]	.....
4.2.16 Striker is provided in the vicinity of the cabinet.	[ ]	[ ]	[ ]	.....
4.2.17 Suitable guide ring is provided to permit easy withdrawal of the hose reel tubing.	[ ]	[ ]	[ ]	.....
4.2.18 An operation instruction is affixed prominently adjacent to each hose reel.	[ ]	[ ]	[ ]	.....

	Yes	No	N/A	Remarks
4.2.19 The notice is clearly marked with the standard wordings in English and Chinese characters of at least 5 mm high in red letters on white background or vice versa.	[ ]	[ ]	[ ]	.....
4.2.20 Manual fire alarm call points are sited at a prominent position near the hose reels.	[ ]	[ ]	[ ]	.....
4.2.21 The manual fire alarm call points are not more than 1 200 mm above the finished floor level.	[ ]	[ ]	[ ]	.....
4.2.22 Upon actuation of any manual fire alarm call point in the building, the fixed fire pump shall come into operation regardless of the zoning of the fire alarm call point.	[ ]	[ ]	[ ]	.....
4.2.23 Door fitted to the hose reel cabinet.	[ ]	[ ]	[ ]	.....
4.2.23.1 Such doors cause no undue obstruction and no interference with any exit point when in open position.	[ ]	[ ]	[ ]	.....
4.2.23.2 Such doors cause no obstruction to the hose being run out in either directions.	[ ]	[ ]	[ ]	.....
4.2.23.3 Such doors bear the words "FIRE HOSE REEL" (消防喉轆) of at least 50 mm high.	[ ]	[ ]	[ ]	.....
4.2.23.4 No locking device is fitted to such doors.	[ ]	[ ]	[ ]	.....
4.2.23.5 Control valves and nozzles are sited in a discernible and accessible position of not more than 500 mm from the surface of the doors.	[ ]	[ ]	[ ]	.....
4.2.23.6 Operation instruction notice is affixed immediately below the words "FIRE HOSE REEL" on the outer surface of the door.	[ ]	[ ]	[ ]	.....
4.2.24 Hose reel of swinging cradle type.	[ ]	[ ]	[ ]	.....
4.2.24.1 When not in use the outer face of the reel is flush with the wall.	[ ]	[ ]	[ ]	.....
4.2.24.2 When required for use the cradle can be swung freely into the corridor or passage.	[ ]	[ ]	[ ]	.....
4.3 SUPPLY TANK				
4.3.1 Correct location and adequate capacity of water tank.	[ ]	[ ]	[ ]	.....
4.3.2 Refilling system is in efficient working order.	[ ]	[ ]	[ ]	.....
4.3.3 Fire Service Completion Advice issued.	[ ]	[ ]	[ ]	.....

4.4 FIXED FIRE PUMP		Yes	No	N/A	Remarks
4.4.1	Mode of power for driving the pump is:				
4.4.1.1	Electricity [ ] or .....				
4.4.2	Secondary power supply provided.	[ ]	[ ]	[ ]	.....
4.4.2.1	If no, diesel engine driven standby pump provided.	[ ]	[ ]	[ ]	.....
4.4.3	Where the motive power for any pump is not electricity, alternative means of starting the pump manually, in addition to manual fire alarm call points, are provided.	[ ]	[ ]	[ ]	.....
4.4.4	Starting instructions for diesel driven pump are prominently displayed in the pump room.	[ ]	[ ]	[ ]	.....
4.4.5	No automatic means of stopping the pump, other than by switching off at the pump control installed near the pump.	[ ]	[ ]	[ ]	.....
4.4.6	Manual fire alarm call points are wired for starting the pump.	[ ]	[ ]	[ ]	.....
4.4.7	The pumps are duplicated for duty and standby use.	[ ]	[ ]	[ ]	.....
4.4.8	The fire pump starters are wired through a selector switch for duty and standby pump selection.	[ ]	[ ]	[ ]	.....
4.4.9	The standby pump is energized within 15 seconds upon failure of the duty pump.	[ ]	[ ]	[ ]	.....
4.4.10	The motor/engine for the pump is rated to give 20% more power in addition to the hydraulic power required for the rated flow of the system.	[ ]	[ ]	[ ]	.....
4.4.11	Pumps are permanently primed.	[ ]	[ ]	[ ]	.....
4.4.12	Non-return valve(s) are provided to prevent water backflow into the water tank.	[ ]	[ ]	[ ]	.....
4.4.13	The status of each fire pump comprising "Power Supply On", "Pump Running" and "Pump Failed" are monitored and displayed at the pump control panel in the pump room.	[ ]	[ ]	[ ]	.....
4.4.14	Such signals are repeated to:	[ ]	[ ]	[ ]	.....
	Fire control centre [ ] or				
	A status panel at the main entrance of the building [ ]				

	Yes	No	N/A	Remarks
4.4.15 All fire pumps are housed in suitable enclosures and designed solely for accommodating pumps for fire service installations.	[ ]	[ ]	[ ]	.....
4.4.16 Pump enclosures are laid clear of any exit or normal communication routes through the premises.	[ ]	[ ]	[ ]	.....
4.4.17 Pump enclosures are clearly marked in English and Chinese characters.	[ ]	[ ]	[ ]	.....
4.4.18 Pumps enclosures are suitably locked to prevent unauthorized tampering of the pumps.	[ ]	[ ]	[ ]	.....
4.4.19 Flow rate and pressure tested in accordance with Figure No. .... in ANNEX I.	[ ]	[ ]	[ ]	.....
Floor level of tested hydrant .....				
Flow(l/min): .....				
Pressure (kPa): .....				
4.4.20 Running and static pressure at any hydrant outlet not exceeding 850 kPa.	[ ]	[ ]	[ ]	.....
4.5 INTERMEDIATE BOOSTER PUMP	[ ]	[ ]	[ ]	.....
4.5.1 Height between the topmost hydrant and the lowest F.S. inlet (m): .....				
4.5.2 No. of rising main: .....				
4.5.3 Required aggregate flow (l/min):.....				
4.5.4 The pumps are duplicated for duty and standby use.	[ ]	[ ]	[ ]	.....
4.5.5 The standby pump is energized within 15 seconds upon failure of the duty pump.	[ ]	[ ]	[ ]	.....
4.5.6 Intermediate booster pump arrangements:—				
4.5.6.1 One set consisting of duty and standby to feed all rising mains in the same system.	[ ]	[ ]	[ ]	.....
4.5.6.2 Two/three pumps of same capacity using sequential starting as duty pumps with one standby to achieve required flow and pressure within 30 seconds.	[ ]	[ ]	[ ]	.....
4.5.7 The motors driving the pumps are rated to give 20% more power in addition to the hydraulic power required for the rated flow.	[ ]	[ ]	[ ]	.....
4.5.8 All pumps are permanently primed and electrically driven.	[ ]	[ ]	[ ]	.....
4.5.9 Pump continues to run irrespective of power interruption when start button is activated.	[ ]	[ ]	[ ]	.....



	Yes	No	N/A	Remarks
4.5.10 Start/stop push buttons with pump running indication light and buzzer provided adjacent to the fire service inlet.	<input type="checkbox"/>	<input type="checkbox"/>	<input type="checkbox"/>	.....
4.5.11 The status of each fire pump comprising "Power Supply On", "Pump Running" and "Pump Failed" are monitored and displayed at the pump control panels in the pump enclosures.	<input type="checkbox"/>	<input type="checkbox"/>	<input type="checkbox"/>	.....
4.5.12 Such signals are repeated to:	<input type="checkbox"/>	<input type="checkbox"/>	<input type="checkbox"/>	.....
Fire control centre <input type="checkbox"/> or				
A status panel at the main entrance of the building <input type="checkbox"/>				
4.5.13 All fire pumps are housed in suitable enclosures and designed solely for accommodating pumps for fire service installations.	<input type="checkbox"/>	<input type="checkbox"/>	<input type="checkbox"/>	.....
4.5.14 Pump enclosures are suitably locked and laid clear of any exit or normal communication routes through the premises.	<input type="checkbox"/>	<input type="checkbox"/>	<input type="checkbox"/>	.....
4.5.15 Pump enclosures are clearly marked in English and Chinese characters.	<input type="checkbox"/>	<input type="checkbox"/>	<input type="checkbox"/>	.....
4.5.16 The intermediate booster pump utilized as the fixed fire pump.	<input type="checkbox"/>	<input type="checkbox"/>	<input type="checkbox"/>	.....
4.5.17 Flow rate and pressure tested in accordance with Figure No. .... in ANNEX I.	<input type="checkbox"/>	<input type="checkbox"/>	<input type="checkbox"/>	.....
Floor level of tested hydrant: .....				
Flow (l/min):.....				
Pressure (kPa): .....				
4.5.18 Running and static pressure at any hydrant outlet not exceeding 850 kPa.	<input type="checkbox"/>	<input type="checkbox"/>	<input type="checkbox"/>	.....
4.6 RISING MAIN				
4.6.1 The nominal bore of the rising main, in the case of industrial/godown buildings:				
Not less than 100 mm	<input type="checkbox"/>	<input type="checkbox"/>	<input type="checkbox"/>	.....
Each rising main supplies two hydrant outlets per floor	<input type="checkbox"/>	<input type="checkbox"/>	<input type="checkbox"/>	.....
4.6.2 The nominal bore of the rising main in other types of buildings:	<input type="checkbox"/>	<input type="checkbox"/>	<input type="checkbox"/>	.....
Not less than 80 mm	<input type="checkbox"/>	<input type="checkbox"/>	<input type="checkbox"/>	.....
Each rising main supplies one hydrant outlet per floor	<input type="checkbox"/>	<input type="checkbox"/>	<input type="checkbox"/>	.....

	Yes	No	N/A	Remarks
4.6.3 Provision of by-pass for intermediate booster pump.	[ ]	[ ]	[ ]	.....
4.6.4 All rising and down-coming mains are permanently primed.	[ ]	[ ]	[ ]	.....
4.6.5 Suitable air relief valves provided.	[ ]	[ ]	[ ]	.....
4.6.6 Each rising main is connected to a fire service inlet.	[ ]	[ ]	[ ]	.....
4.6.7 Header pipe(s) provided to connect the fire service inlets to the rising mains.	[ ]	[ ]	[ ]	.....
4.6.8 The diameter of the header pipe is:				
For industrial/godown buildings not less than 150 mm nominal bore	[ ]	[ ]	[ ]	.....
For other buildings not less than 100 mm nominal bore	[ ]	[ ]	[ ]	.....
4.6.9 For godown/industrial buildings, a rising main provided for each staircase with a fire service inlet.	[ ]	[ ]	[ ]	.....
4.6.10 Number and location of fire service inlets are conforming to latest approved building plan.	[ ]	[ ]	[ ]	.....
4.7 FIRE SERVICE INLET				
4.7.1 Suitably enclosed and protected.	[ ]	[ ]	[ ]	.....
4.7.2 Readily accessible by Fire Services personnel.	[ ]	[ ]	[ ]	.....
4.7.3 Centre of coupling not less than 600 mm nor more than 1 000 mm above ground level.	[ ]	[ ]	[ ]	.....
4.7.4 A non-return valve provided for each inlet.	[ ]	[ ]	[ ]	.....
4.7.5 Each inlet is affixed with a metal identification plate raised or engraved with English and Chinese characters.	[ ]	[ ]	[ ]	.....
4.7.6 The frontage of each inlet enclosure is clearly and permanently indicated in English and Chinese characters "FS INLET" (消防入水掣) of not less than 50 mm high.	[ ]	[ ]	[ ]	.....

V. *GENERAL COMMENTS & REMARKS*

---

---

---

---

---

---

Test witnessed by:—

..... (Signature)

..... (Signature)

..... (Name in block letters)  
FSI Contractor's Representative

..... (Name in block letters)  
Fire Services Inspecting Officer

Date .....

Date .....

**ANNEX I – FIGURES FOR EQUIPMENT ARRANGEMENT  
FOR TESTING OF FIRE PUMPS**

GENERAL NOTES : -

- (i) THE FLOW MEASURING DEVICE(S) MAY BE PLACED AT ROOF LEVEL FOR CONVENIENT DISCHARGE OF WATER.
- (ii) ALL HYDRANTS UNDER TEST SHALL BE FULLY OPENED.
- (iii) THE PRESSURE GAUGE SHALL BE SITUATED ADJACENT TO THE HYDRANT OUTLET UNDER TEST.

LEGEND :

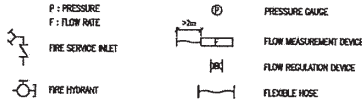

**1. FIXED FIRE PUMP** (BUILDINGS OTHER THAN INDUSTRIAL / GODOWN – 14, 800 l/min)  
(ANY OF THE FOLLOWING ARRANGEMENTS SHALL BE FOLLOWED)

FIG. 1.1

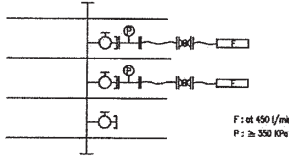

FIG. 1.2

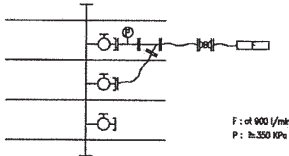
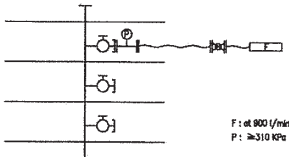
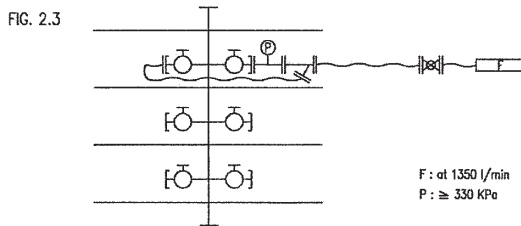
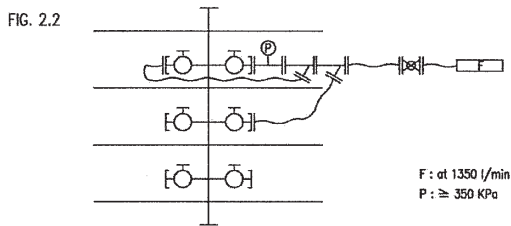
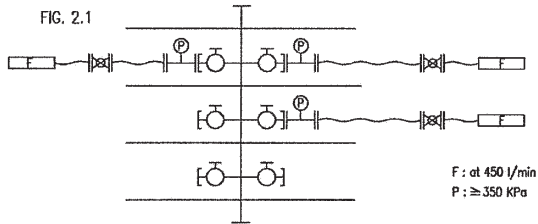

FIG. 1.3



2. FIXED FIRE PUMP (INDUSTRIAL / GODOWN BUILDINGS)  
(ANY OF THE FOLLOWING ARRANGEMENTS SHALL BE FOLLOWED)



3. INTERMEDIATE BOOSTER PUMP (BUILDINGS OTHER THAN INDUSTRIAL/ GODOWN)

FIG. 3.1 DOMESTIC AND OTHER BUILDINGS WITH SINGLE RISING MAIN (900 l/min)  
TESTING EQUIPMENT TO BE ARRANGED IN ACCORDANCE WITH (1)

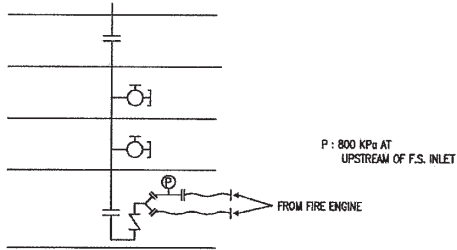
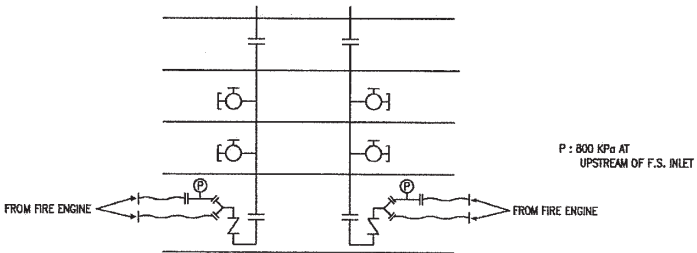

FIG. 3.2 OTHER BUILDINGS WITH TWO OR MORE RISING MAINS (1800 l/min)  
TWO SETS OF RISING MAIN SHALL BE TESTED SIMULTANEOUSLY IN ACCORDANCE WITH (1)



4. INTERMEDIATE BOOSTER PUMP (INDUSTRIAL / GOODOWN BUILDINGS)

FIG. 4.1 SINGLE RISING MAIN (1350 l/min)

TESTING EQUIPMENT TO BE ARRANGED IN ACCORDANCE WITH (2)

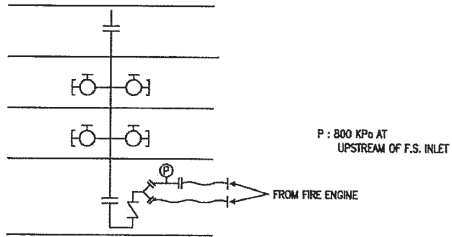
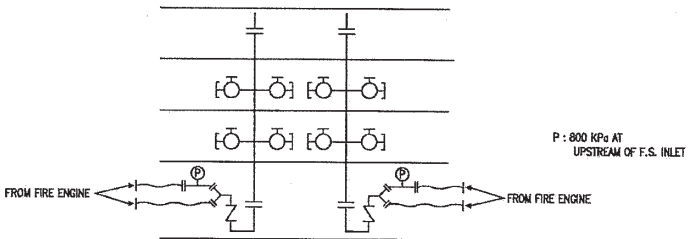

FIG. 4.2 TWO OR MORE RISING MAINS (2700 l/min)

TWO SETS OF RISING MAIN SHALL BE TESTED SIMULTANEOUSLY IN ACCORDANCE WITH (2)



**Checklist for Staircase Pressurization System**

**Reference**

Address: ..... FSD Ref: .....  
 ..... FP 19/20/43/47/78\* .....

FSD Acceptance Letter/Approval Date: .....

FSI Working Drawing Ref. : .....

Approved Building Plan Ref.: ..... Dated: .....

**Section I – General items for all staircase pressurization systems installed in the building**

**1.1 Measuring and testing instrument / equipment calibration**

Measuring instrument used for testing purpose shall be provided in duplicate and calibrated in the past 3 months.

	<u>Type</u>	<u>Model No.</u>	<u>Serial No.</u>	<u>Calibration Cert. No.</u>	<u>Remarks</u>
a.	.....	.....	.....	.....	.....
b.	.....	.....	.....	.....	.....
c.	.....	.....	.....	.....	.....
d.	.....	.....	.....	.....	.....
e.	.....	.....	.....	.....	.....
f.	.....	.....	.....	.....	.....
g.	.....	.....	.....	.....	.....
h.	.....	.....	.....	.....	.....
i.	.....	.....	.....	.....	.....
j.	.....	.....	.....	.....	.....

**1.2 Documentation**

		Yes	No	Remarks
a.	Equipment list of staircase pressurization system c/w related test report is attached.	[ ]	[ ]	.....
b.	Equipment list of builder’s work (such as doorset, door closer & etc.) c/w related test report is attached.	[ ]	[ ]	.....
c.	Certifying the building air tightness condition during the testing is equivalent to the occupation condition.	[ ]	[ ]	.....

**1.3 Staircase pressurization working drawings against building plans**

		Yes	No	N/A	Remarks
a.	Classifications of pressurized spaces for means of escape / firefighting & rescue tally with approved building plans.	[ ]	[ ]	[ ]	.....
b.	Designations of staircase number and fireman’s lift number, fire fighting access number tally with approved building plans.	[ ]	[ ]	[ ]	.....
c.	Locations of staircase pressurization plant rooms tally with approved building plans.	[ ]	[ ]	[ ]	.....
d.	Fire resistance rating of plant rooms is same as the pressurized space.	[ ]	[ ]	[ ]	.....
e.	Air intake positions tally with approved building plans.	[ ]	[ ]	[ ]	.....
f.	Discharge positions of over pressure relief tally with approved building plans.	[ ]	[ ]	[ ]	.....

*\* Delete as appropriate*



**Section II – For each staircase pressurization system only**  
**(Separate copy of Section II should be attached to respective pressurization system)**

**2.1 Description**

- a. Designation of pressurized staircase  
(The designation should be the same as building plan & FSI drawing & test report.)
- b. Pressurized space :- (Please tick as appropriate)
  - Escape staircase; or
  - Fire fighting staircase
- c. Equipment to be provided :-
  - Single fan with motor; or
  - Duplicate fans complete with motors; or
  - Single fan with duplicate motors
- d. Design air velocity passes through the door between pressurized space and accommodation area ..... m/s
- e. Design differential pressure between the pressurized space and accommodation ..... Pa
- f. Design door opening force ..... N ( $\leq 100N$ )

**2.2 Test report**

(All systems should be tested and endorsed by registered professional engineer before final test with Fire Services Inspecting Officer.)

	Appendix	Remarks
a. Pressure test report of all ductwork (including builder's work, ducts, shafts or other construction)	.....	.....
b. Air velocity measurement report	.....	.....
c. Door opening force measurement report	.....	.....
d. Differential pressure measurement report	.....	.....
e. System performance test report	.....	.....

**2.3 Visual inspection**

	Yes	No	N/A	Remarks
a. <u>Air intake</u> (Item a.1 to a.5 for air intake not located at roof floor)				
a.1 Notice in English & Chinese characters "Staircase pressurization intake for (pressurized space)" (增壓空間的樓梯增壓入風口) is provided.	<input type="checkbox"/>	<input type="checkbox"/>	<input type="checkbox"/>	.....
a.2 Position of air intake is located away from any potential fire hazards (such as basement smoke vent).	<input type="checkbox"/>	<input type="checkbox"/>	<input type="checkbox"/>	.....
a.3 Air duct is provided from the intake to the fan when air intake is distant from the fan.	<input type="checkbox"/>	<input type="checkbox"/>	<input type="checkbox"/>	.....
a.4 A smoke detector of a type suitable for use in air duct / plenum is installed.	<input type="checkbox"/>	<input type="checkbox"/>	<input type="checkbox"/>	.....
a.5 Pressurization system can be shut down when the duct type smoke detector is activated.	<input type="checkbox"/>	<input type="checkbox"/>	<input type="checkbox"/>	.....
(Items a.6 to a.13 for air intake located at roof floor)				
a.6 Two air intakes, which spaced apart and facing different directions, are provided.	<input type="checkbox"/>	<input type="checkbox"/>	<input type="checkbox"/>	.....

	Yes	No	N/A	Remarks
a.7 Each intake is capable of providing the full air requirements of the system.	[ ]	[ ]	[ ]	.....
a.8 Independently operated smoke control damper with duct type smoke detector is provided at each intake.	[ ]	[ ]	[ ]	.....
a.9 An override switch to reopen the closed damper and to close the open damper is provided.	[ ]	[ ]	[ ]	.....
a.10 No smoke discharge within 5 m of any direction of air intake.	[ ]	[ ]	[ ]	.....
a.11 Notice in Chinese & English characters "Staircase pressurization intake for (pressurization space)" (樓梯增壓入風口) is provided.	[ ]	[ ]	[ ]	.....
a.12 Air duct is provided from the intake to the fan when air intake is distant from the fan.	[ ]	[ ]	[ ]	.....
a.13 Smoke control damper properly actuated when duct type smoke detector activated.	[ ]	[ ]	[ ]	.....
b. <u>Plant room</u>				
b.1 No other service inside the plant room.	[ ]	[ ]	[ ]	.....
b.2 Minimum fire resistance rating for the enclosure of the pressurization plant is equal to or greater than the pressurized space served (FRR of enclosure is ..... hrs.)	[ ]	[ ]	[ ]	.....
b.3 When plant room served more than one pressurization system, separate fire rated enclosure is provided to each pressurization system in order to maintain fire compartmentation between different pressurized spaces.	[ ]	[ ]	[ ]	.....
b.4 When fan room is used as an air plenum, all control panels should be located outside the fan room, or protected by fire resistant enclosure(s).	[ ]	[ ]	[ ]	.....
c. <u>Air injection point &amp; associated ductwork</u>				
c.1 Multiple injection points are provided when the pressurized staircase exceeds 11m.	[ ]	[ ]	[ ]	.....
c.2 Vertical distance between injection points is not greater than 12 m or three storeys.	[ ]	[ ]	[ ]	.....
c.3 Volume control dampers of air injection points are properly secured.	[ ]	[ ]	[ ]	.....
c.4 Injection duct work passing through other fire compartment is constructed to have the same FRR required for either the pressurized space or the compartment through it passes, whichever is the greater.	[ ]	[ ]	[ ]	.....
c.5 An injection point of a single injection point system is away from the final exit door.	[ ]	[ ]	[ ]	.....
c.6 Ductwork construction is complied with or not less than DW144 standard.	[ ]	[ ]	[ ]	.....
c.7 Aluminium sheet and aluminium pop rivet shall not be provided in flat oval duct longer than 1 m.	[ ]	[ ]	[ ]	.....
d. <u>Air release system</u>				
d.1 Spread of smoke between different fire compartments does not likely happen in both normal operation and fail safe mode.	[ ]	[ ]	[ ]	.....
d.2 When the operation of air release system is automatic, it is actuated by the same detector / device that actuates the rest of the pressurization system.	[ ]	[ ]	[ ]	.....

	Yes	No	N/A	Remarks
d.3 When the accommodation space is partitioned or compartmented into offices or similar unit, the air relief vent is provided at:-				
i. Between the door into pressurized space and the start of the partitioning;	[ ]	[ ]	[ ]	-----
or				
ii. On each offices & units, the size of each air relief vent is capable of discharging the total air flow from pressurized space.	[ ]	[ ]	[ ]	
d.4 Air release vent is located at or immediately below ceiling level	[ ]	[ ]	[ ]	-----
Type of air release system				
- Vertical shaft (go to d5 – d6);	[ ]	or		
- Special vents at the building periphery (go to d7 – d9);	[ ]	or		
- Mechanical air release (go to d10 – d12).	[ ]			
d.5 Top vent is provided at the vertical shaft.	[ ]	[ ]	[ ]	-----
d.6 When the shaft is designed for dual propose, automatic control fire & smoke damper is provided at each branch duct.	[ ]	[ ]	[ ]	-----
d.7 Special vents for external vent are provided on at least two sides of the sealed building.	[ ]	[ ]	[ ]	-----
d.8 Fail safe protection is provided to the ventilator.	[ ]	[ ]	[ ]	-----
d.9 Components of ventilator are compliant with BS7346-1/ BS7346-2.	[ ]	[ ]	[ ]	-----
d.10 Extraction flow rate is greater than the total pressurized air flow rate of all served staircase pressurization systems.	[ ]	[ ]	[ ]	-----
d.11 Extraction system including ductwork is capable of working at the appropriate temperature and period of time (250°C for 1 hour for building with sprinkler system, 600°C for 2 hour for building without sprinkler system).	[ ]	[ ]	[ ]	-----
d.12 The following items should be complied with, when the central exhaust system also serves for mechanical air release:-				
i. Component & ductwork of central exhaust system is capable of working at the appropriate temperature and period of time (250°C for 1 hour for building with sprinkler system, 600°C for 2 hour for building without sprinkler system);	[ ]	[ ]	[ ]	-----
and				
ii. When the related pressurization system is actuated, function of VAC control system and VAC manual override switch for shutting down the central exhaust system is ignored;				
and	[ ]	[ ]	[ ]	-----
iii. For pressurization system for fire fighting, the local motorized smoke damper in fire floor is opened and dampers for other compartments / units is closed;				
or				
For pressurization system for escape, the local motorized smoke damper in fire floor and two above floor should be opened and dampers for other compartments / units are closed.	[ ]	[ ]	[ ]	-----

	Yes	No	N/A	Remarks
e. <u>Over pressure relief system</u>				
Type of over pressure relief system				
- Automatic opening of the external exit doors on operation of the fan (go to e1 – e2);	[ ]	or		
- Barometric pressure relief vents / damper (go to e3 – e5);	[ ]	or		
- Mechanical exhaust (go to e6 – e7).	[ ]			
e.1 Door lock, latch, bolt, push bar & etc. are not provided at the external exit doors	[ ]	[ ]	[ ]	-----
e.2 Warning label: “Over pressure relief door. Do not obstruct” (超壓時放壓門，不要阻塞) is provided in English and Chinese characters at the external exit doors	[ ]	[ ]	[ ]	-----
e.3 Wire mesh is provided at the external opening of relief vent / damper.	[ ]	[ ]	[ ]	-----
e.4 Relief vent / duct passed through other fire compartment is enclosed by fire rated material; the FRR should be same of pressurized space or the compartment through it passes, whichever is greater.	[ ]	[ ]	[ ]	-----
e.5 Free area of relief vent / damper “A <sub>x</sub> ” $\geq 0.16 \text{ m}^2 \times$ (total required airflow (m <sup>3</sup> /s) through the open doors – air supply satisfying the pressure differential requirement (m <sup>3</sup> /s) in pressurized space) <i>*See equation (24) of section 14 of BS 5588: Part 4: 1988*</i>	[ ]	[ ]	[ ]	-----
e.6 Fan can be activated by differential pressure sensor	[ ]	[ ]	[ ]	-----
e.7 Fan directly discharges to external or the discharge ductwork is constructed with fire rated material when passing through other fire compartment. The FRR of ductwork should be same as that of pressurized space or fire compartment passed, whichever is greater.	[ ]	[ ]	[ ]	-----
f. <u>Electrical &amp; control</u>				
f.1 Electrical supplies for all equipment (such as fans, air relief damper, over pressure device, controller, supervisory panel & etc.) are fed from the same essential source.	[ ]	[ ]	[ ]	-----
f.2 Requirement of main switchboard and/or local control panel :-				
- Construction is complied with BS 5486 from not less than 2 mm panel steel and is installed in a room having ..... hour FRR (including self-closing doors) without other equipment installed therein; or	[ ]	[ ]	[ ]	-----
- All controls, starters, relays, etc. shall be suitable for continuous operation at 250°C for not less than 1 hour.	[ ]	[ ]	[ ]	-----
f.3 Requirement of power supply cable for pressurized system, controller, pressure sensor & etc.:-				
- BS 6387 Cat. CWZ ; or	[ ]			
- BS 6207 or BS EN 60702; or	[ ]			
- Other international standards acceptable to the Director of Fire Services; or	[ ]			
- Specification complying with criteria for exemption in Appendix 6 of FSD COP for Inspection, Testing and Maintenance of Installations and Equipment. (Items -----)	[ ]			-----
f.4 Separate pressure differential system is provided for each pressurized system.	[ ]	[ ]	[ ]	-----
f.5 End of pressure sensing tube is properly terminated at the pressurized space and accommodation.	[ ]	[ ]	[ ]	-----
f.6 End of sensing tube is mechanically protected.	[ ]	[ ]	[ ]	-----

	Yes	No	N/A	Remarks
f.7 Label of “Sensing point of staircase pressurization system” (樓梯增壓系統感應點) is clearly indicated in English and Chinese characters.	[ ]	[ ]	[ ]	
f.8 Protection is provided along the sensing tube.	[ ]	[ ]	[ ]	
f.9 Power supplies for the differential pressure sensor, control, over pressure device, air release device are distributed from sub-circuit of staircase pressurization system.	[ ]	[ ]	[ ]	
f.10 Manual override switch provided on local fan control panel is locked in “Automatic control” position.	[ ]	[ ]	[ ]	
f.11 An indication signal is transmitted to supervisory control panel, when local fan control panel is in manual control mode.	[ ]	[ ]	[ ]	
g. <u>Construction work</u>				
g.1 Installations of door sets providing access to or from any pressurized space satisfy Building Authority’s requirements.	[ ]	[ ]	[ ]	
g.2 All doors, closers, hardware, etc. are capable of use in an atmosphere of 35°C & 100% R.H.	[ ]	[ ]	[ ]	
g.3 No supplementary gasket is provided to assist in preventing smoke leakage.	[ ]	[ ]	[ ]	
g.4 Door sets are installed in such a manner to be smoke leakage proof.	[ ]	[ ]	[ ]	
g.5 All joints between frames & building structure are provided with sealants in compliance with BS 476: Part 23.	[ ]	[ ]	[ ]	
g.6 Self-closing door closers are provided for all doors.	[ ]	[ ]	[ ]	
g.7 Finished sill under the closed doors is wear resistant.	[ ]	[ ]	[ ]	
h. <u>Functional test</u>				
h.1 Performance test is carried out and the result is satisfactory.	[ ]	[ ]	[ ]	
h.2 Measurement of door opening force is carried out and result is satisfactory.	[ ]	[ ]	[ ]	
h.3 Measurement of differential pressure across the pressurized space and accommodation is carried out and the result is satisfactory.	[ ]	[ ]	[ ]	
h.4 Measurement of pressurized air flow is carried out and the result is satisfactory.	[ ]	[ ]	[ ]	
h.5 Air intake fire/smoke damper is closed when the duct type smoke detector is activated;	[ ]	[ ]	[ ]	
or				
Staircase pressurization system is shut down when the duct smoke detector at air intake is activated (for air intake only facing in one direction).	[ ]	[ ]	[ ]	
h.6 In order to prevent over pressure in pressurized space, fail safe protection for over pressure release is provided on conditions of :-				
- Failure of controller.	[ ]	[ ]	[ ]	
- Failure of pressure switch.	[ ]	[ ]	[ ]	
- Failure of wiring of pressure switch.	[ ]	[ ]	[ ]	
- Failure of actuator of by-pass damper.	[ ]	[ ]	[ ]	
- Failure of wiring of actuator (by-pass damper).	[ ]	[ ]	[ ]	
- Failure of over pressure exhaust fan.	[ ]	[ ]	[ ]	

	Yes	No	N/A	Remarks
<b>h.7 Functional test of actuation</b>				
- by building fire alarm system is in order. (Note: Manual fire alarm is not recommended for air relief system which is automatically controlled in the fire zones)	[ ]	[ ]	[ ]	
- by smoke detection system is in order.	[ ]	[ ]	[ ]	
- by sprinkler system is in order.	[ ]	[ ]	[ ]	
- by point type smoke detector mounted in the accommodation area adjacent to the doors (within 1 m) leading to the protected space at each storey served by the system is in order.	[ ]	[ ]	[ ]	
- by supervisory control panel when selected in manual mode is in order.	[ ]	[ ]	[ ]	
<b>h.8 Functional test of response time</b>				
The system is capable of achieving between 90% & 110% of the new volumetric requirements within 5 sec. of a door being opened or closed (for the over pressure release system by using variable supply fans or dampers).	[ ]	[ ]	[ ]	
<b>h.9 Changeover from the duty equipment to the standby equipment is automatically operated when failure occurred in duty equipment.</b>	[ ]	[ ]	[ ]	

**Section III –For all staircase pressurization system installed in the building**

- 3.1 The checklist is totally ..... pages (including attached copies of Section II for each additional staircase pressurization system).
- 3.2 Attached ..... number(s) of appendix.

Tested by :

Signature : .....

Name of Installation Contractor : .....

Company Chop : .....

Date : .....

Certified by :

Signature : .....

Full Name of Registered Professional Engineer : .....

Register Number of Engineer : .....

Company Chop : .....

Date : .....

## APPENDIX 7

## Checklist for Street Fire Hydrant System

## I. REFERENCE

Project .....	FSD Ref. ....
Address .....	Location .....
.....	.....

## II. TYPE OF SYSTEM

	Yes	No	N/A	Remarks
2.1 Supplied Directly from Town Main	[ ]	[ ]	[ ]	.....
2.2 Supplied from Gravity Tank	[ ]	[ ]	[ ]	.....
2.3 Supplied from Pumps and Tank	[ ]	[ ]	[ ]	.....
2.4 Supplied from Sea Water Pumps	[ ]	[ ]	[ ]	.....

## III. LAYOUT CHECKING AGAINST APPROVED BUILDING PLANS

FSD Ref. of Approved Building Plans.....	Tally with drawings?			
	Yes	No	N/A	Remarks
3.1 Quantity of street hydrants	[ ]	[ ]	[ ]	.....
3.2 Location of street hydrants	[ ]	[ ]	[ ]	.....
3.3 Location of pump room/enclosure	[ ]	[ ]	[ ]	.....
3.4 Location of tank	[ ]	[ ]	[ ]	.....
3.5 Tank capacity	[ ]	[ ]	[ ]	.....

## IV. ON SITE INSPECTION

## 4.1 GENERAL

4.1.1 Hydrant body is painted in red for fresh water system and in yellow for sea water system (with white band when fed directly from government trunk main).	[ ]	[ ]	[ ]	.....
4.1.2 For hydrant not in service, cap for 100mm outlet is painted in blue.	[ ]	[ ]	[ ]	.....
4.1.3 Each hydrant is equipped with a control valve.	[ ]	[ ]	[ ]	.....
4.1.4 Each hydrant is equipped with an isolating valve (applicable to system fed directly/indirectly from government main).	[ ]	[ ]	[ ]	.....
4.1.5 Spindle of underground hydrant valve is within 250 mm to 500 mm below valve pit cover.	[ ]	[ ]	[ ]	.....
4.1.6 Size of underground control valve pit cover is not greater than 300 mm x 300 mm with "FH" marking engraved on the surface. (Remarks: Isolating valve pit cover shall conform to WSD standard.)	[ ]	[ ]	[ ]	.....

	Yes	No	N/A	Remarks
4.1.7 The valve pit of control valve is located between 1.5 m to 3 m from the street hydrant.	[ ]	[ ]	[ ]	.....
4.1.8 The valve pit of control valve is located outside the designated emergency vehicular access.	[ ]	[ ]	[ ]	.....
4.1.9 V-shaped arrow head (100 mm high and 50 mm wide) pointing toward the control valve is painted on hydrant top (yellow arrow for red hydrant and red arrow for yellow hydrant).	[ ]	[ ]	[ ]	.....
4.1.10 The hydrant number with size not less than 75 mm is painted at the hydrant (in yellow for red hydrant and in red for yellow hydrant).	[ ]	[ ]	[ ]	.....
4.1.11 There is no obstruction within 1.5 m in front and on two sides of the hydrant.	[ ]	[ ]	[ ]	.....
4.1.12 Tank refilling system is in efficient working order (applicable to system with tank).	[ ]	[ ]	[ ]	.....
4.1.13 The number assigned for the hydrant shall be painted on the body facing the roadway with size not less than 75 mm (in yellow for red hydrant and in red for yellow hydrant).	[ ]	[ ]	[ ]	.....
4.2 PUMP (if provided)				
4.2.1 Duplicate pumps are provided for duty and standby use.	[ ]	[ ]	[ ]	.....
4.2.2 Mode of power for driving the pump is:				
4.2.2.1 Electricity [ ] or .....				
4.2.2.2 Secondary power supply provided.	[ ]	[ ]	[ ]	.....
4.2.2.3 If no, diesel engine driven standby pump provided.	[ ]	[ ]	[ ]	.....
4.2.2.4 Starting instruction for diesel engine driven pump are prominently displayed in the pump room enclosure.	[ ]	[ ]	[ ]	.....
4.2.3 No automatic means of stopping the pump other than by switching off at the pump room/enclosure.	[ ]	[ ]	[ ]	.....
4.2.4 For duplicate electric motor driven pump arrangement, the pump starters are wired through a selector switch for duty and standby pump selection.	[ ]	[ ]	[ ]	.....
4.2.5 The motor/engine for the pump is rated to give 20% more power in addition to the hydraulic power required for the rated flow of the system.	[ ]	[ ]	[ ]	.....
4.2.6 Pumps are permanently primed.	[ ]	[ ]	[ ]	.....



	Yes	No	N/A	Remarks
4.2.7 Non-return valve(s) are provided to prevent water backflow into the water tank if provided.	[ ]	[ ]	[ ]	.....
4.2.8 All pumps are housed in suitable room/enclosure designed solely for accommodating pumps or equipment for fire service installations.	[ ]	[ ]	[ ]	.....
4.2.9 Pump room/enclosure are laid clear of any exit or normal communication routes through the premises.	[ ]	[ ]	[ ]	.....
4.2.10 Pump room/enclosure is clearly marked in English and Chinese characters.	[ ]	[ ]	[ ]	.....
4.2.11 Pump room/enclosure is suitably locked to prevent unauthorised tampering.	[ ]	[ ]	[ ]	.....
4.3 SUPPLY TANK (if provided)				
4.3.1 Water tank and its capacity are clearly marked in English and Chinese characters.	[ ]	[ ]	[ ]	.....
4.3.2 Fire Service Completion Advice issued.	[ ]	[ ]	[ ]	.....
4.3.3 For system where the tank bottom is more than 20m above the outlet coupling of the lowest street hydrant, a bypass pipe (of the same size as the pump suction pipe) is provided at the pump suction and discharge pipe. (Please see Figure C in Annex I)	[ ]	[ ]	[ ]	.....

*SYSTEM TESTING*

(applicable to system with pumps)

5.1 The pump starts automatically upon opening of any hydrant outlet.	[ ]	[ ]	[ ]	.....
5.2 Other than the jockey pump, the pump can only be stopped manually at the pump room, once started.	[ ]	[ ]	[ ]	.....
5.3 The standby pump is energized within 15 seconds upon failure of the duty pump.	[ ]	[ ]	[ ]	.....
5.4 For diesel engine driven pump, the operation of the pump starting pressure switch is not affected by mains power failure.	[ ]	[ ]	[ ]	.....
5.5 The status of each pump comprising "Power Supply On", "Pump Running" and "Pump Failed" are monitored and displayed at the pump room.	[ ]	[ ]	[ ]	.....
5.6 The pump status signals are repeated to: Fire control centre	[ ]	or		
A status panel at the building main entrance	[ ]	or		.....

	Yes	No	N/A	Remarks
5.7 Tank refilling system is in efficient working order (applicable to system with tank).	[ ]	[ ]	[ ]	.....

VI. FIELD MEASUREMENTS

- 6.1 Flow rate and pressure tested in accordance with Figure ..... in Annex I.
- 6.2 When discharging at two 65mm outlets simultaneously:
  - Flow at one 65mm outlet (l/min) : .....
  - Running Pressure (kPa) : .....

VII. GENERAL COMMENTS & REMARKS

---



---



---



---



---

Test witnessed by:

.....(Signature)

.....(Signature)

.....(Name in block letters)

.....(Name in block letters)

FSI Contractor's Representative

Fire Services Inspecting Officer

Date.....

Date.....

Annex I

**FIGURES FOR EQUIPMENT ARRANGEMENT FOR TESTING OF PEDESTAL STREET HYDRANT**  
(2 OPTIONS TO SUIT SITE CONDITIONS)

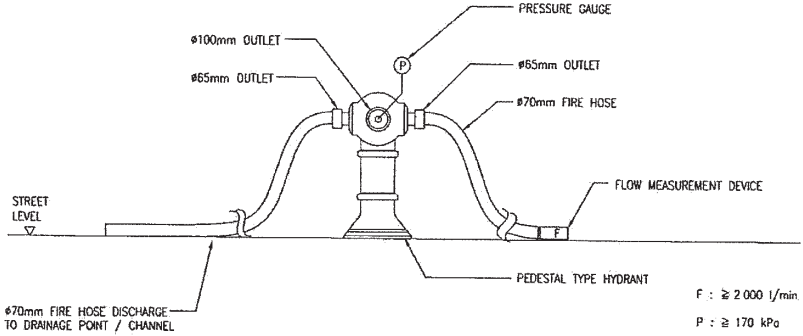

FIGURE A

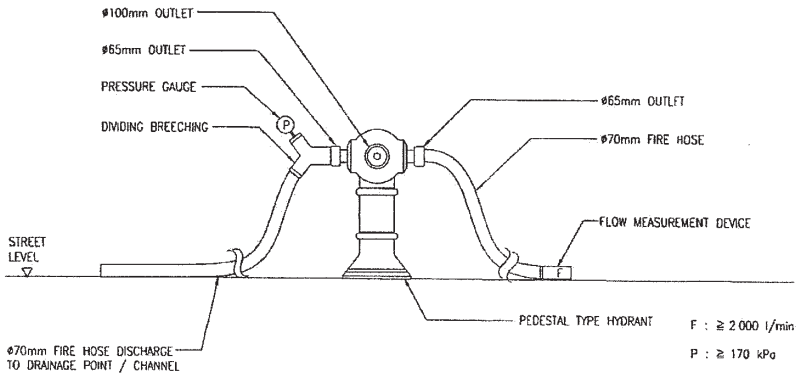

FIGURE B

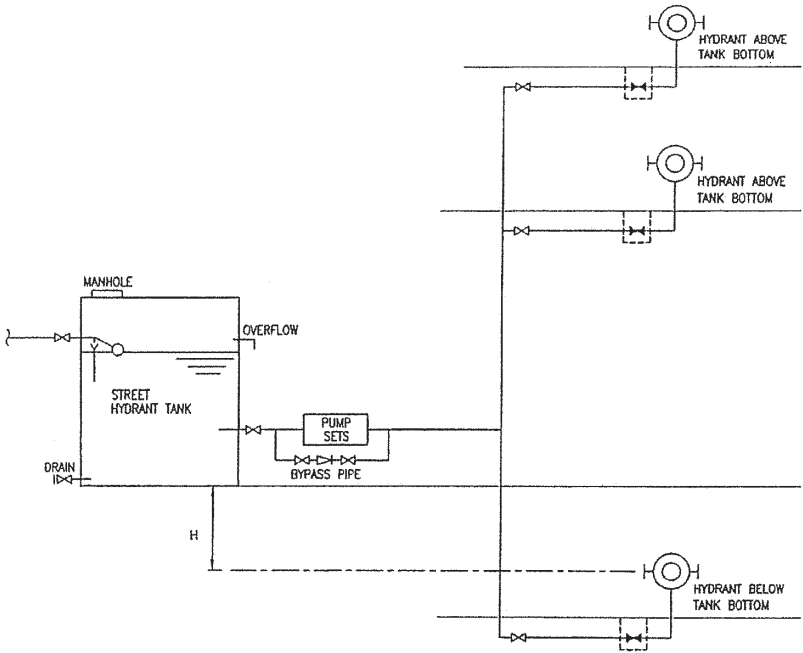

FIGURE C

(SCALE: N.T.S.)

NOTES:

- (1) "H" IS THE HEIGHT DIFFERENCE BETWEEN THE TANK BOTTOM AND THE CENTRE LINE OF THE OUTLET COUPLING OF THE LOWEST STREET HYDRANT IN THE SYSTEM.
- (2) IF  $H > 20\text{m}$ , THEN A BYPASS PIPE IS REQUIRED AT THE PUMP SETS.

## APPENDIX 8

**Minimum Fire Resisting Cable Requirements for Fire Service Installations**

Item	Type of Fire Service Installations	Minimum Cable Requirements
1.	Audio/visual advisory systems	Power supply cables to conform with: (a) BS 6387 Cat. A WX or SWX; or (b) BS 6207 or BS EN 60702; or (c) Other international standards acceptable to the Director of Fire Services.
2.	Automatic fixed installations (other than sprinkler systems) using water	
3.	Deluge systems	
4.	Drencher systems	
5.	Fire alarm systems	
6.	Fire hydrant/hose reel systems	
7.	Fixed foam systems	
8.	Ring main systems with fixed pumps	
9.	Water spray systems	
10.	Emergency generators	Power supply cables (from emergency generator to main switchboard) to conform with: (a) BS 6387 Cat. CWZ; or (b) BS 6207 or BS EN 60702; or (c) Other international standards acceptable to the Director of Fire Services.
11.	Fireman's lifts	Power supply cables (from the main switchboard to the main switch for lift power circuit and car lighting etc., in the lift machine room) to conform with: (a) BS 6387 Cat. CWZ; or (b) BS 6207 or BS EN 60702; or (c) Other international standards acceptable to the Director of Fire Services.
12.	Pressurization of staircases	Power supply cables to conform with: (a) BS 6387 Cat. CWZ; or (b) BS 6207 or BS EN 60702; or (c) Other international standards acceptable to the Director of Fire Services.

Item	Type of Fire Service Installations	Minimum Cable Requirements
13.	Smoke extraction systems	<p>Power supply cables to conform with:            (a) BS 6387 Cat. CWZ; or            (b) BS 6207 or BS EN 60702; or            (c) Other international standards acceptable to the Director of Fire Services.</p> <p>Control cables to conform with:            (a) BS 6387 Cat. AWX or SWX; or            (b) BS 6207 or BS EN 60702; or            (c) Other international standards acceptable to the Director of Fire Services.</p>

Remarks:

Cables under any of the following conditions may be exempted from the above minimum requirements:-

- (a) Cables installed and terminated in switch/plant room;
- (b) Cables inside concealed metallic or PVC conduits which are embedded by plaster/concrete to a depth of at least 12 mm;
- (c) Cables inside underground cable ducts or reinforced concrete cable trenches;
- (d) Cables embedded in the soil to a depth of at least 300 mm;
- (e) Cables within fire resisting cable ducts and are not mixed with other services (e.g. switchgear, etc); the fire resistance rating of cable ducts to be not less than that of the building compartment; or
- (f) Cables inside metallic flexible conduits not exceeding 2 m for final connection to fire service equipment.

## APPENDIX 9

**Shutdown of Fire Service Installations for Inspection, Maintenance, Modification or Repair**Reporting of shutdown of fire service installations (FSI) for inspection, maintenance, modification or repair

1. When a Registered Fire Service Installation Contractor (RFSIC) is employed to repair defective FSI and the repair is expected to be carried out *overnight or for more than 24 hours continuously*, the RFSIC should notify the Fire Services Department (FSD) of the defect(s) as soon as possible after the defect(s) is/are identified literally within 24 hours.

2. When a RFSIC is employed to maintain, modify or repair an FSI which has to be shut down *overnight or for more than 24 hours continuously*, the RFSIC should notify the FSD at least 7 calendar days prior to the commencement of work. Should the period between the date of confirmation that the RFSIC has been employed to carry out the work and the date of commencement of work be less than 7 calendar days, the RFSIC should notify the Fire Services Department (FSD) within 24 hours after such confirmation.

3. If extension of the shutdown period is required, the RFSIC should issue a fresh notification to the FSD before the previous scheduled date of completion. However, if there are changes in the extent and/or portion of the affected system(s), the notification procedure as stated in paragraphs 1 and 2 should be followed.

4. Notification to the FSD as mentioned in paragraphs 1, 2 and 3 should be made by fax using the form attached in **Annex I**. The date of commencement, the anticipated date of completion of the work and the reason(s) for the shutdown of the FSI should be provided. The Fire Services Communications Centre (FSCC) will upon receipt of the form, stamp an FSD serial number on the form and send a copy of the stamped form to the RFSIC. A sample is in **Annex II**.

Preventative measures to mitigate the risk during the works period when any FSI is defective or shut down for inspection, maintenance, modification or repair

5. In addition to the notification mechanism set out in paragraphs 1, 2 and 3, the

following guidelines should be observed by the RFSIC concerned when an FSI is expected to be shut down *overnight or for more than 24 hours continuously* for the purpose of work:

- (a) The residents / occupants / property management company should be notified of the shutdown of the FSI, the date of commencement and the anticipated date of completion of the maintenance / modification / repair.
- (b) Simple and standardized graphical notices detailing the shutdown of the FSI should be posted at prominent locations. A sample of such notice is attached in **Annex III** for compliance.
- (c) The disruption to the normal operation of the FSI caused by maintenance, modification or repair should be kept to the minimum. A systematic approach should be adopted in carrying out the work. The affected FSI should be shut down by sections and be resumed normal as soon as practicable. The impact on the protection afforded by the system should be reduced to the minimum and kept as low as reasonably practicable. If the affected portion of the system cannot be reinstated to normal working condition by the end of a working shift, arrangements should be made for the portion to be isolated and the remainder of the system to be reinstated. Shutting down the whole system for a prolonged period should be avoided.
- (d) Stand-by means\* should be provided at suitable locations. The local fire station should be consulted on the scale of such provision. The local fire station / residents / occupiers / property management company, where appropriate, should be notified of the arrangements.  
*\*Stand-by means such as fire extinguishers, standalone smoke detectors, temporary firefighting water supply system, etc. should be provided according to the extent of fire risk and the area(s) being affected.*
- (e) Shutting down both fire hydrant/hose reel system and sprinkler system simultaneously should be avoided.
- (f) Whenever possible, water tanks of the affected / unaffected systems should be topped up prior to the commencement of work.
- (g) Advice, where appropriate, should be given to the property management company concerned to:
  - (i) formulate an emergency plan;
  - (ii) patrol the affected areas (e.g. 24-hour manning, patrol at 15-minute intervals evidenced by making entries in a record book provided thereat);
  - (iii) designate named personnel to undertake specified tasks, including



- monitoring the progress of repair work, report to the Police / FSD upon the detection of a fire, etc.;
- (iv) place / install additional fire fighting and/or detection equipment with an alarm sounding function such as fire extinguishers, standalone smoke detectors, temporary firefighting water supply system, etc in the affected area(s);
  - (v) arrange sufficient trained staff for operating the FSI / portable equipment and executing the emergency plan;
  - (vi) inspect and review passive and active fire protection measures, including fire doors, gaseous extinguishing systems and portable fire extinguishers. Neither obstruction nor impairment of the available FSI should be allowed;
  - (vii) display suitable notices at prominent locations about the shutdown of the systems;
  - (viii) reduce the stock level of goods, in particular, those highly combustible ones (e.g. flimsy paper products, paints, etc);
  - (ix) suspend any activities that generate sparks, hot molten droplets in the affected areas; and
  - (x) maintain good house keeping.

for official use:-  
 fax to FSITF/LC  
 fax to Fire Station

Annex I

To : FSCC  
 致 : 消防通訊中心  
 Fire Services Department 消防處  
 Fax No. : 2311 0066  
 傳真號碼

Date : \_\_\_\_\_  
 日期  
 FSD File No. : \_\_\_\_\_  
 消防處檔案編號 (If known 如果知道)

**Notification to FSD on the Occasion that Building FSI is Shut Down for Work**  
**樓宇消防裝置因工程而關閉通知書**

**Part I 第一部**

Building Name 樓宇名稱 : _____ Building Address 樓宇地址 : _____	(Hong Kong 香港 / Kowloon 九龍 / New Territories 新界)
Incorporated Owners (I.O.) : YES / NO 業主立案法團 有 沒有	I.O. Tel. No. : _____ 業主立案法團電話
FSI Required to be Shut Down 需關閉的消防裝置 :	
<input type="checkbox"/> Fire Hydrant / Hose Reel System 消防栓 / 喉籠系統	<input type="checkbox"/> Street Fire Hydrant 街上消防栓(私家街井)
<input type="checkbox"/> Automatic Sprinkler System 花灑系統	<input type="checkbox"/> Water Spray System 噴水系統
<input type="checkbox"/> Fire Detection System (AFA) 火警偵測系統	<input type="checkbox"/> Manual Fire Alarm System 火警警報系統
<input type="checkbox"/> Others 其他 (Please specify 請註明) : _____	
Reason for Shutdown 關閉原因 : <input type="checkbox"/> Defective 損壞	<input type="checkbox"/> Others 其他 (Please specify 請註明) : _____
Brief Description of Work 工程簡述 : _____	
Portion(s) of FSI Involved : _____ 受影響消防裝置部份	Portion(s) of Building Involved : _____ 受影響樓宇部份
Date Commenced : _____ 開始日期	Estimated Completion Date : _____ 預計完工日期
Date of Contract for Repair/Maintenance 獲得維修/保養合約的日期 : _____	
The following standby measures will be provided at the following locations 以下備用設備將會放置在下列位置 :	
The following parties have been notified of the arrangement 有關安排已通知下列人士 :	
<input type="checkbox"/> Residents 居民 <input type="checkbox"/> Occupiers 佔用人 <input type="checkbox"/> Management Company 物業管理公司 <input type="checkbox"/> Incorporated Owners 業主立案法團	
Name of FSI / Work Contractor : _____ 消防裝置 / 工程承辦商名稱	<b>Signature &amp; Company Chop</b> 簽名及公司印
Registration No. (FSI Contractor Only) : _____ 承辦商級別 / 編號 (祇適用於消防裝置承辦商)	
Contact Tel. No. : _____ (Office 寫字樓)	
聯絡電話 : _____ (Mobile Phone 手提電話 / Pager 傳呼機)	
Fax No. 傳真號碼 : _____	
* The local fire station will contact you for arrangement of inspection and discussion of the proposed contingency measures. 有關消防局將會聯絡你, 安排巡查及討論建議的應變措施。	

**Part II 第二部 - Extension of the Shutdown Period for Work 工程延期通知**

The above FSI has to be shut down until _____ (date) due to _____ 以上消防裝置需關閉至 _____ (日期)。原因: _____	<b>Signature &amp; Company Chop</b> 簽名及公司印
--	---

**Part III 第三部 (To be completed upon full or partial completion of work and faxed to FSCC again)  
 在全部或部份完工時請填寫此欄, 然後再傳真到消防通訊中心。**

#Full/Partial Completion of Work #全部/部份完工 (#Delete whichever not applicable 刪除不適用) Date 日期 : _____ FSI 消防裝置 : _____	<b>Signature &amp; Company Chop</b> 簽名及公司印
---	---

Remark: FSCC will confirm receipt of this notification by returning it by fax which is stamped with an FSD serial number.  
 備註: 消防通訊中心會以加上編號蓋印的回覆傳真確認收受這份通知書。

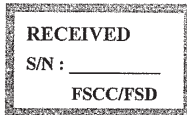

for official use:- <input type="checkbox"/> fax to FSITF/LC <input type="checkbox"/> fax to Fire Station
--

Annex II

To : FSCC  
 致 : 消防通訊中心  
 Fire Services Department 消防處  
 Fax No. : 2311 0066  
 傳真號碼

Date : \_\_\_\_\_  
 日期  
 FSD File No. : \_\_\_\_\_  
 消防處檔案編號 (If known 如果知道)

**Notification to FSD on the Occasion that Building FSI is Shut Down for Work**  
 樓宇消防裝置因工程而關閉通知書

**Part I 第一部**

Building Name 樓宇名稱 :	_____		
Building Address 樓宇地址 :	_____		
(Hong Kong 香港 / Kowloon 九龍 / New Territories 新界)			
Incorporated Owners (I.O.) :	YES / NO	I.O. Tel. No. :	_____
業主立案法團	有 沒有	業主立案法團電話	_____
FSI Required to be Shut Down 需關閉的消防裝置 :			
<input type="checkbox"/> Fire Hydrant / Hose Reel System 消防栓 / 喉轆系統	<input type="checkbox"/> Street Fire Hydrant 街上消防栓(私家街井)	<input type="checkbox"/> Fire Detection System (AFA) 火警偵測系統	<input type="checkbox"/> Manual Fire Alarm System 火警警報系統
<input type="checkbox"/> Automatic Sprinkler System 花灑系統	<input type="checkbox"/> Water Spray System 噴水系統	<input type="checkbox"/> Others 其他 (Please specify 請註明) : _____	
Reason for Shutdown 關閉原因 : <input type="checkbox"/> Defective 損壞 <input type="checkbox"/> Others 其他 (Please specify 請註明) : _____			
Brief Description of Work 工程簡述 : _____			
Portion(s) of FSI Involved : 受影響消防裝置部份		Portion(s) of Building Involved : 受影響樓宇部份	
Date Commenced : 開始日期		Estimated Completion Date : 預計完工日期	
Date of Contract for Repair/Maintenance 獲得維修/保養合約的日期 : _____			
The following standby measures will be provided at the following locations 以下備用設備將會放置在下列位置 :			
The following parties have been notified of the arrangement 有關安排已通知下列人士 :			
<input type="checkbox"/> Residents 居民 <input type="checkbox"/> Occupiers 佔用人 <input type="checkbox"/> Management Company 物業管理公司 <input type="checkbox"/> Incorporated Owners 業主立案法團			
Name of FSI / Work Contractor : 消防裝置 / 工程承辦商名稱	<b>Signature &amp; Company Chop</b> <b>簽名及公司印</b>		
Registration No. (FSI Contractor Only) : 承辦商級別 / 編號 (祇適用於消防裝置承辦商)			
Contact Tel. No. : _____ (Office 寫字樓)			
聯絡電話 _____ (Mobile Phone 手提電話 / Pager 傳呼機)			
Fax No. 傳真號碼 : _____			
* The local fire station will contact you for arrangement of inspection and discussion of the proposed contingency measures. 有關消防局將會聯絡你, 安排巡查及討論建議的應變措施。			

**Part II 第二部 - Extension of the Shutdown Period for Work 工程延期通知**

The above FSI has to be shut down until _____ (date) due to _____	<b>Signature &amp; Company Chop</b> <b>簽名及公司印</b>
以上消防裝置需關閉至 _____ (日期), 原因: _____	

**Part III 第三部** (To be completed upon full or partial completion of work and faxed to FSCC again)

#Full/Partial Completion of Work #全部/部份完工 (#Delete whichever not applicable 刪除不適用) Date 日期 : _____ FSI 消防裝置 : _____	<b>Signature &amp; Company Chop</b> <b>簽名及公司印</b>
_____	

**Remark: FSCC will confirm receipt of this notification by returning it by fax which is stamped with an FSD serial number.**  
 備註: 消防通訊中心會以加上編號蓋印的回覆傳真確認收受這份通知書。

## Annex III

不少於30厘米

消防裝置維修工程通告







由 年 月 日至 年 月 日  
將進行消防裝置維修／檢查工程，  
下列消防裝置須暫停操作。

承辦商名稱： \_\_\_\_\_

緊急聯絡電話： \_\_\_\_\_

下列消防裝置將暫停操作（請刪除不適合項目）：

不少於  
45厘米

- 消防栓／喉轆系統  （涉及樓層／部份 \_\_\_\_\_）
- 花灑系統  （涉及樓層／部份 \_\_\_\_\_）
- 火警警報系統  （涉及樓層／部份 \_\_\_\_\_）
- 火警偵測系統  （涉及樓層／部份 \_\_\_\_\_）
- 應急照明系統  （涉及樓層／部份 \_\_\_\_\_）
- 其他（請註明） \_\_\_\_\_

如發生火警，請立即致電999及通知物業管理處職員

## APPENDIX 10

**Statutory Requirements for Maintenance, Inspection and Repair of FSI and Examination, Testing and Certification of Gas Cylinders Used as FSI**

Installation / Equipment	Type of Maintenance Work	Person Authorized by FSD for Maintenance Work
FSI (other than portable equipment)	Annual inspection	RFSIC
	Maintenance / Repair	Class 1 and/or Class 2
Pressure cylinder <sup>1</sup> of an FSI	Hydraulic pressure test every 5 years	Approved Person <sup>3</sup> for examination, testing and certification of gas cylinders
	Charging	Person holding a licence for the manufacture of relevant dangerous goods
Portable equipment <sup>2</sup>	Annual inspection	RFSIC Class 3
	Hydraulic pressure test every 5 years	
	Refilling of extinguishing agent and/or charging of fire extinguishers <i>other than</i> CO <sub>2</sub> gas and clean agent fire extinguishers	
	Charging of CO <sub>2</sub> gas and clean agent fire extinguishers	Supplier of portable equipment (Person holding a licence for the manufacture of relevant dangerous goods)

**Remarks:**

1. Required to be approved by FSD under r.64 of the Dangerous Goods (General) Regulations, Cap. 295B
2. Required to be approved under r.3 of the Fire Service (Installations and Equipment) Regulations, Cap. 95B
3. List of Approved Persons for examination, testing and certification of gas cylinders to be referred to FSD webpage :

*[http://www.hkfsd.gov.hk/home/eng/source/approved\\_person\\_66\\_67\\_DGO.pdf](http://www.hkfsd.gov.hk/home/eng/source/approved_person_66_67_DGO.pdf)*

## APPENDIX 11

**Notes on Fire Extinguishers, Fire Blankets and Sand Buckets  
(Suitability and Maintenance)****I. CARBON DIOXIDE TYPE EXTINGUISHERS****Use:**

On electrical fires, flammable liquids, delicate equipment, important documents, or fires in confined spaces.

**Note:**

Vapours will asphyxiate. Withdraw to open air after use.

**Maintenance:**

This type of extinguisher should be examined every 12 months and the following maintenance carried out:-

- (i) The total weight should be checked against that recorded when the extinguisher was put into service. If a loss of weight of more than 10 per cent is detected, the extinguisher should be discharged and returned to the supplier for examination, test and recharging.
- (ii) The body of the extinguisher should be examined and, if there are signs of damage or extensive external corrosion, the extinguisher should be discharged and returned to supplier for examination, test and recharging.
- (iii) The discharge horn and hose should be checked to see that it moves freely and should be replaced if damaged is detected.
- (iv) Hydraulic pressure test should be carried out every five years on the cylinder in accordance with the manufacturer's instructions. Extreme care should be exercised when preparing and conducting the test.
- (v) Unserviceable extinguisher should be discharged prior to disposal.

## II. WATER TYPE EXTINGUISHERS

Use:

On fires involving woods, textiles and paper.

Never:

On fires involving electrical or flammable liquids or metals.

Maintenance:

This type of extinguisher should be examined every 12 months and the following maintenance carried out:-

### (GAS-CARTRIDGE TYPE)

- (i) The vent holes in the cap should be checked for cleanliness and free from obstruction.
- (ii) Remove the headcap to check the liquid level. The liquid should be topped up as necessary.
- (iii) The nozzle, strainer and internal discharge tube should be checked for cleanliness and free from obstruction. Defective items shall be replaced.
- (iv) The gas cartridge should be weighed and the weight checked against that marked on the cartridge. The cartridge should be renewed if a loss of more than 10 per cent of the contents is recorded.
- (v) No corrosion, damage or rust should be visible either externally or internally. Special attention should be paid to the concealed parts of the container.
- (vi) Before the headcap is replaced and while the gas cartridge is unscrewed therefrom, the plunger or other operating device should be checked to see that it operates freely. The washer should be examined and replaced if necessary. The cap should then be tightly screwed to the container to form a gas-tight joint.
- (vii) Test 50 per cent of extinguishers by discharge every year in rotation so that all extinguishers are tested by discharge every two years. Should any extinguisher fail in the test, all cartridges in the remainder should be replaced. Extreme care should be exercised during preparing and conducting discharge test. Prior to discharging, the container should be ensured in good condition such as no corrosion, damage or rust should be visible externally or internally on any part of the container; otherwise hydraulic pressure test should then be carried out to confirm the container structurally sound. Should there be doubt about the condition of the container, hydraulic pressure test shall be conducted instead.
- (viii) Corroded parts should be cleaned up and refinished after the hydraulic pressure test.
- (ix) Hydraulic pressure test should be carried out every five years on the container in accordance with the manufacturer's instructions. Extreme care should be exercised when preparing and conducting the test.

- (x) Before carrying out hydraulic pressure test, remove the headcap, disconnect the gas cartridge and clear the contents. Never empty the contents by discharging the extinguisher.
- (xi) Also, before disposal of unserviceable fire extinguisher, remove the headcap, disconnect the gas cartridge and clear the contents. Never empty the contents by discharging the extinguisher.

(STORED-PRESSURE TYPE)

- (i) The pressure indicating device should be checked to see the correct pressure is being maintained within the extinguisher body.
- (ii) The nozzle or branch-pipe (if fitted) and the pressure releasing valve in the cap should be checked for cleanliness and free from obstruction. Defective items shall be replaced.
- (iii) No corrosion, damage or rust should be visible externally on any part of the container. Special attention should be paid to the concealed parts of the container.
- (iv) Test 50 per cent of extinguishers by discharge every year in rotation so that all extinguishers are tested by discharge every two years. Should any extinguisher fail in the test, all extinguishers should be overhauled and recharged.
- (v) Prior to recharging, the container should be ensured in good condition such as no corrosion, damage or rust was noted; otherwise hydraulic pressure test should be conducted to confirm the container structurally sound.
- (vi) Hydraulic pressure test should be carried out every five years on the container in accordance with the manufacturer's instructions. Extreme care should be exercised when preparing and conducting the test.
- (vii) Unserviceable extinguisher should be discharged prior to disposal.



### III. DRY POWDER TYPE EXTINGUISHERS

Use:

On most fires, flammable liquids, metal fires or electrical fires.

Maintenance:

This type of extinguisher should be examined every 12 months and the following maintenance carried out:-

#### (GAS-CARTRIDGE TYPE)

- (i) The vent holes in the cap should be checked for cleanliness and free from obstruction.
- (ii) The extinguisher should be weighed to check that it contains the correct weight of powder. The weight when fully charged should be recorded at the time of charging. If the weight is found to have dropped by more than 10 per cent, the dry powder should be replaced by a fresh charge. Care should be taken not to mix different types of dry powder because they could react with one another.
- (iii) The powder should be agitated to ensure it is free from caking.
- (iv) Remove the headcap to check the condition of powder. The chemical should be renewed if it is not in good condition.
- (v) The nozzle and discharge control (if fitted) should be checked for cleanliness and free from obstruction. Defective items shall be replaced.
- (vi) The gas cartridge should be weighed and the weight checked against that marked on the cartridge. The cartridge should be renewed if a loss of more than 10 per cent of the contents is recorded.
- (vii) No corrosion, damage or rust should be visible either externally or internally. Special attention should be paid to the concealed parts of the container.
- (viii) Before the headcap is replaced and while the gas cartridge is unscrewed therefrom, the plunger or other operating device should be checked to see that it operates freely. The washer should be examined and replaced if necessary. The cap should then be tightly screwed to the container to form a gas-tight joint.
- (ix) Test 50 per cent of extinguishers by discharge every year in rotation so that all extinguishers are tested by discharge every two years. Should any extinguisher fail in the test, all cartridges in the remainder should be replaced. Extreme care should be exercised during preparing and conducting discharge test. Prior to discharging, the container should be ensured in good condition such as no corrosion, damage or rust should be visible externally or internally on any part of the container; otherwise hydraulic pressure test should then be carried out to confirm the container structurally sound. Should there be doubt about the condition of the container, hydraulic pressure test shall be conducted instead.
- (x) Corroded parts should be cleaned up and refinished after the hydraulic pressure test.

- (xi) Hydraulic pressure test should be carried out every five years on the container in accordance with the manufacturer's instructions. Extreme care should be exercised when preparing and conducting the test.
- (xii) Before carrying out hydraulic pressure test, remove the headcap, disconnect the gas cartridge and the dry powder should be collected for subsequent re-cycling/disposal. Never empty the contents by discharging the extinguisher.
- (xiii) Also, before disposal of unserviceable fire extinguisher, remove the headcap, disconnect the gas cartridge and the dry powder should be collected for subsequent re-cycling/disposal. Never empty the contents by discharging the extinguisher.

(STORED-PRESSURE TYPE)

- (i) The extinguisher should be weighed to check it contains the correct weight of powder. If the weight is found to have dropped by more than 10 per cent, the dry powder should be replaced by a fresh charge. Care should be taken not to mix different types of dry powder because they could react with one another.
- (ii) The pressure indicating device should be checked to see the correct pressure is being maintained within the extinguisher body.
- (iii) The nozzle or branch-pipe (if fitted) and the pressure releasing valve in the cap should be checked for cleanliness and free from obstruction. Defective items shall be replaced.
- (iv) No corrosion, damage or rust should be visible externally on any part of the container. Special attention should be paid to the concealed parts of the container.
- (v) Test 50 per cent of extinguishers by discharge every year in rotation so that all extinguishers are tested by discharge every two years. The dry powder should be discharged to an enclosure for collection and subsequent re-cycling/disposal. Should any extinguisher fail in the test, all extinguishers should be overhauled and recharged.
- (vi) Prior to recharging, the container should be ensured in good condition such as no corrosion, damage or rust was noted; otherwise hydraulic pressure test should be conducted to confirm the container structurally sound.
- (vii) Hydraulic pressure test should be carried out every five years on the container in accordance with the manufacturer's instructions. Extreme care should be exercised when preparing and conducting the test.
- (viii) Unserviceable extinguisher should be discharged prior to disposal. The dry powder should be discharged to an enclosure for collection and subsequent re-cycling/disposal.

NOTE:

- (a) Dry powder extinguishers must be thoroughly dry internally before they are recharged.
- (b) Advice should be obtained from the Fire Services Department as to the possible reaction between the powder or expellant and the material protected.

#### IV. CLEAN AGENT FIRE EXTINGUISHERS

Use:

On electrical fires, flammable liquids, delicate equipment, important documents.

Maintenance:

This type of extinguisher should be examined every 12 months and the following maintenance carried out:-

##### (PORTABLE TYPE)

- (i) The pressure indicating device should be checked to see the correct pressure is being maintained within the extinguisher body.
- (ii) The extinguisher should be weighed to check against the total weight record when it is put into service. If a loss of weight of more than 10 per cent is detected, the extinguisher should be discharged to a closed recycling system and returned to the supplier for examination, test and recharging.
- (iii) The nozzle or branch-pipe (if fitted) and the pressure releasing valve in the cap should be checked for cleanliness and free from obstruction. Defective items shall be replaced.
- (iv) No corrosion, damage or rust should be visible externally on any part of the container. Special attention should be paid to the concealed parts of the container.
- (v) If there are signs of damage or external corrosion, the extinguisher should be discharged to a closed recycling system and returned to the supplier for examination, test and recharging.
- (vi) Hydraulic pressure test should be carried out every five years on the container in accordance with the manufacturer's instructions. Extreme care should be exercised when preparing and conducting the test.
- (vii) Unserviceable extinguisher should be discharged to a closed recycling system prior to disposal.

##### (FIXED SPRAYER UNIT)

- (i) The pressure indicating device (if fitted) should be checked to see the correct pressure is being maintained within the extinguisher body.
- (ii) The extinguisher should be weighed to check against the total weight record when it is put into service. If a loss of weight of more than 10 per cent is detected, the extinguisher should be discharged to a closed recycling system and returned to the supplier for examination, test and recharging.
- (iii) The deflector and the sensing element should be checked and cleaned.
- (iv) No corrosion, damage or rust should be visible externally on any part of the container. Special attention should be paid to the concealed parts of the container.

- (v) If there are signs of damage or external corrosion, the extinguisher should be discharged to a closed recycling system and returned to the supplier for examination, test and recharging.
- (vi) Hydraulic pressure test should be carried out every five years on the container in accordance with the manufacturer's instructions. Extreme care should be exercised when preparing and conducting the test.
- (vii) Unserviceable extinguisher should be discharged to a closed recycling system prior to disposal.

**V. FOAM (CHEMICAL) TYPE EXTINGUISHERS**

Use:

On fires involving flammable liquids.

Never:

On electrical fires.

Maintenance:

This type of extinguisher should be examined every 12 months and the following maintenance carried out:-

- (i) The nozzle and the vent holes in the cap should be checked for cleanliness and free from obstruction.
- (ii) Remove the headcap to check the liquid levels in the body and in the inner container. Any slight loss may be made up with water; otherwise a new charge should be used.
- (iii) No corrosion, damage or rust should be visible either externally or internally. Special attention should be paid to the concealed parts of the container.
- (iv) Before the headcap is replaced, the plunger, the headcap lever for the sealing device or other operating device should be checked to see that it operates freely. The washer should be replaced if necessary and the cap should then be tightly screwed to the container to form a gas-tight joint.
- (v) Test 50 per cent of extinguishers by discharge every year in rotation so that all extinguishers are tested by discharge every two years. Should any extinguisher fail in the test, all should be tested by discharge. Extreme care should be exercised during preparing and conducting discharge test. Prior to discharging, the container should be ensured in good condition such as no corrosion, damage or rust should be visible externally or internally on any part of the container; otherwise hydraulic pressure test should then be carried out to confirm the container structurally sound. Should there be doubt in the condition of the container, hydraulic pressure test shall be conducted instead.
- (vi) Corroded parts should be cleaned up and refinished after the hydraulic pressure test.
- (vii) Hydraulic pressure test should be carried out every five years on the outer container in accordance with the manufacturer's instructions; the inner container should be examined to ensure it is in good condition and not leaking. Extreme care should be exercised when preparing and conducting the test.
- (viii) Before carrying out hydraulic pressure test, remove the headcap and clear the contents. Never empty the contents by discharging the extinguisher.
- (ix) Also, before disposal of unserviceable extinguisher, remove the headcap and clear the contents. Never empty the contents by discharging the extinguisher.

NOTE:

Inverted type chemical foam extinguishers have ceased production and not permitted for sale. However, products already sold may continued to be used.

## VI. FOAM (MECHANICAL) TYPE EXTINGUISHERS

Use:

On fires involving flammable liquids.

Never:

On electrical fires.

Maintenance:

This type of extinguisher should be examined every 12 months and the following maintenance carried out:-

### (GAS-CARTRIDGE TYPE)

- (i) The vent holes in the cap should be checked for cleanliness and free from obstruction.
- (ii) Remove the headcap to check the liquid level. If the liquid level was found to have dropped by more than 10 per cent, the foam concentrate or foam solution as appropriate should be replaced by a fresh charge.
- (iii) The branchpipe, strainer and internal discharge tube should be checked for cleanliness and free from obstruction. Defective items shall be replaced.
- (iv) The gas cartridge should be weighed and the weight checked against that marked on the cartridge. The cartridge should be renewed if a loss of more than 10 per cent of the contents is recorded.
- (v) No corrosion, damage or rust should be visible either externally or internally. Special attention should be paid to the concealed parts of the container.
- (vi) Before the headcap is replaced and while the gas cartridge is unscrewed therefrom, the plunger or other operating device should be checked to see that it operates freely. The washer should be examined and replaced if necessary. The cap should then be tightly screwed to the container to form a gas-tight joint.
- (vii) Test 50 per cent of extinguishers by discharge every year in rotation so that all extinguishers are tested by discharge every two years. Should any extinguisher fail in the test, all cartridges in the remainder should be replaced. Extreme care should be exercised during preparing and conducting discharge test. Prior to discharging, the container should be ensured in good condition such as no corrosion, damage or rust should be visible externally or internally on any part of the container; otherwise hydraulic pressure test should then be carried out to confirm the container structurally sound. Should there be doubt about the condition of the container, hydraulic pressure test shall be conducted instead.
- (viii) Corroded parts should be cleaned up and refinished after the hydraulic pressure test.
- (ix) Hydraulic pressure test should be carried out every five years on the container in accordance with the manufacturer's instructions. Extreme care should be exercised when preparing and conducting the test.

- (x) Before carrying out hydraulic pressure test, remove the headcap, disconnect the gas cartridge and clear the contents. Never empty the contents by discharging the extinguisher.
- (xi) Also, before disposal of unserviceable fire extinguisher, remove the headcap, disconnect the gas cartridge and clear the contents. Never empty the contents by discharging the extinguisher.

(STORED-PRESSURE TYPE)

- (i) The pressure indicating device should be checked to see the correct pressure is being maintained within the extinguisher body.
- (ii) The nozzle or branch-pipe (if fitted) and the pressure releasing valve in the cap should be checked for cleanliness and free from obstruction. Defective items shall be replaced.
- (iii) No corrosion, damage or rust should be visible externally on any part of the container. Special attention should be paid to the concealed parts of the container.
- (iv) Test 50 per cent of extinguishers by discharge every year in rotation so that all extinguishers are tested by discharge every two years. Should any extinguisher failed in the test, all extinguishers should be overhauled and recharged.
- (v) Prior to recharging, the container should be ensured in good condition such as no corrosion, damage or rust was noted; otherwise hydraulic pressure test should be conducted to confirm the container structurally sound.
- (vi) Hydraulic pressure test should be carried out every five years on the container in accordance with the manufacturer's instructions. Extreme care should be exercised when preparing and conducting the test.
- (vii) Unserviceable extinguisher should be discharged prior to disposal.

**VII. FIRE BLANKETS****Use:**

On fires involving flammable liquids, such as small fires in the kitchen and laboratory.

**Method for Use:**

Drape the blanket over the flames to seal off air. Switch off heat and leave in position until cool.

**Maintenance:**

This blanket should be examined every 12 months or after use in fire. The following maintenance should be carried out:-

- (i) Check for any deterioration.
- (ii) Cleaning in accordance with the manufacturer's instructions as when necessary.
- (iii) If manufacturer's instructions are not available, fire blanket can be washed (soak overnight in detergent, gently hand rinse in warm water). Do not machine wash or dry clean.

**REMARKS:**

- (i) Fire blankets are classified into two categories, namely:-  
"Heavy Duty" fire blankets (BS 7944:1999); and  
"Light Duty" fire blankets (BS EN 1869:1997)
- (ii) Only "Heavy Duty" and "reusable" fire blankets will be approved as a Fire Services standard requirement.
- (iii) "Light Duty" fire blankets may be accepted for use on a private basis and should be disposed of after use.



**VIII. SAND BUCKETS**

Use:

On fires involving flammable liquids.

Method for Use:

Pour the content in the bucket over spilled flammable liquids to control the flow of spilled flammable liquids.

Maintenance:

Sand bucket should be examined every 12 months or after use in fire. The following maintenance should be carried out:-

(METAL SAND BUCKET)

- (i) The condition of metal sand bucket together with its cover should be examined.
- (ii) Repaint in red colour and re-label in English and Chinese where necessary.
- (iii) Seriously corroded unit should be replaced.
- (iv) Check the sand level inside the bucket and refill the bucket where necessary.
- (v) Wet sand should be dried up.

(PLASTIC SAND BUCKET)

- (i) The condition of plastic sand bucket together with its cover should be examined.
- (ii) Re-label in English and Chinese where necessary.
- (iii) Deteriorated unit should be replaced.
- (iv) Check the sand level inside the bucket and refill the bucket where necessary.
- (v) Wet sand should be dried up.

IX. SAMPLE MAINTENANCE LABEL (保養標籤樣本)

